

Safety Railing

SMOKE VENT FALL PROTECTION

Babcock-Davis' OSHA compliant Safety Railing is ideal for new and retrofit applications. The safety railing mounts to the existing smoke vent curb counterflash without penetrating the membrane or curb.

FEATURES

FALL PROTECTION In accordance with OSHA regulations, the safety railing is engineered to guard smoke vent openings to protect against falls.

EASY FIELD INSTALLATION No field cutting required as rails cut to exact size. Easy assembly fittings and quick mounting on counterflash through curb.

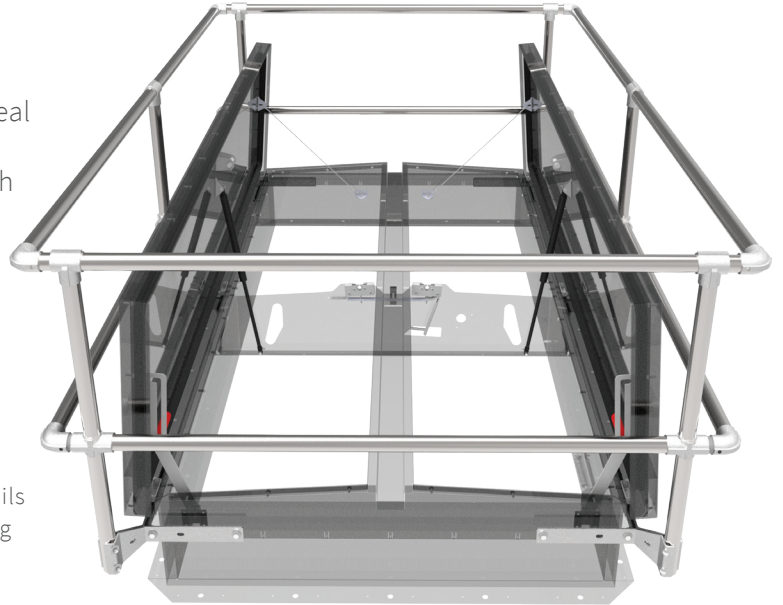

DETAILS

MATERIAL Rails and posts, aluminum, 1-1/4 inch ID (1.66 inch) Schedule 40 pipe

FITTINGS Cast aluminum alloy with set screw hold

MOUNTING BRACKETS 3/16 inch steel, zinc plated with nut backing plate

HARDWARE Hex head bolts 3/8 inch - 16 x 3/4 inch zinc plated steel

COMPLIANCE OSHA 29 CFR 1910.28 and 1910.29

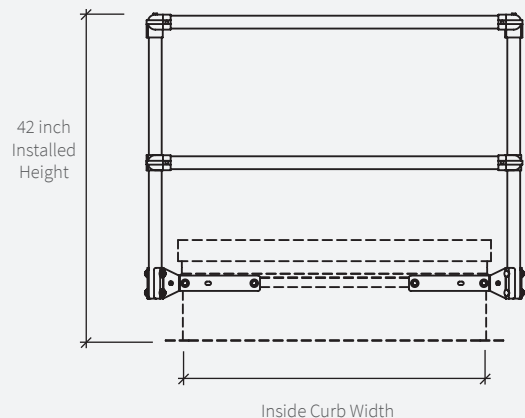

ORDER GUIDE

4-SIDED		2-SIDED	
MODEL	SIZE (IN.)	MODEL	SIZE (IN.)
SRVAY36X30NN	36 x 30	SRVAY48XNNTN	48
SRVAY36X36NN	36 x 36	SRVAY60XNNTN	60
SRVAY48X48NN	48 x 48	SRVAY72XNNTN	72
SRVAY48X96NN	48 x 96		
SRVAY60X96NN	60 x 96		
SRVAY60X120NN	60 x 120		
SRVAY60X144NN	60 x 144		
SRVAY72X144NN	72 x 144		