

B

B

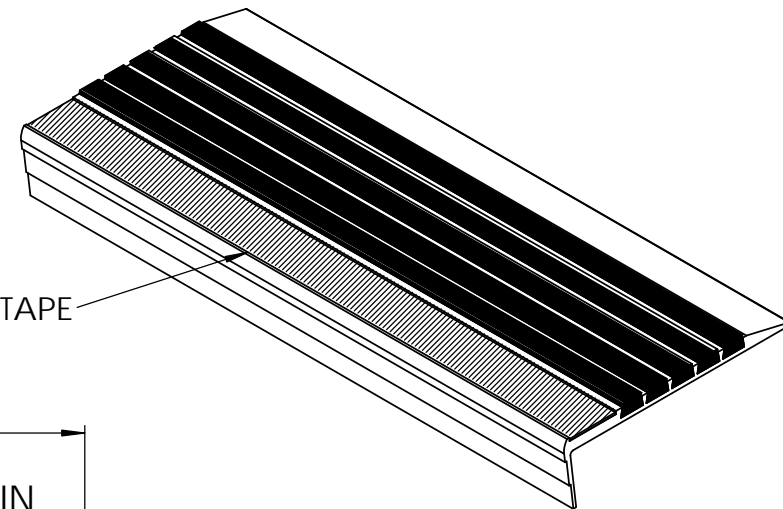

PHOTOLUMINESCENT TAPE

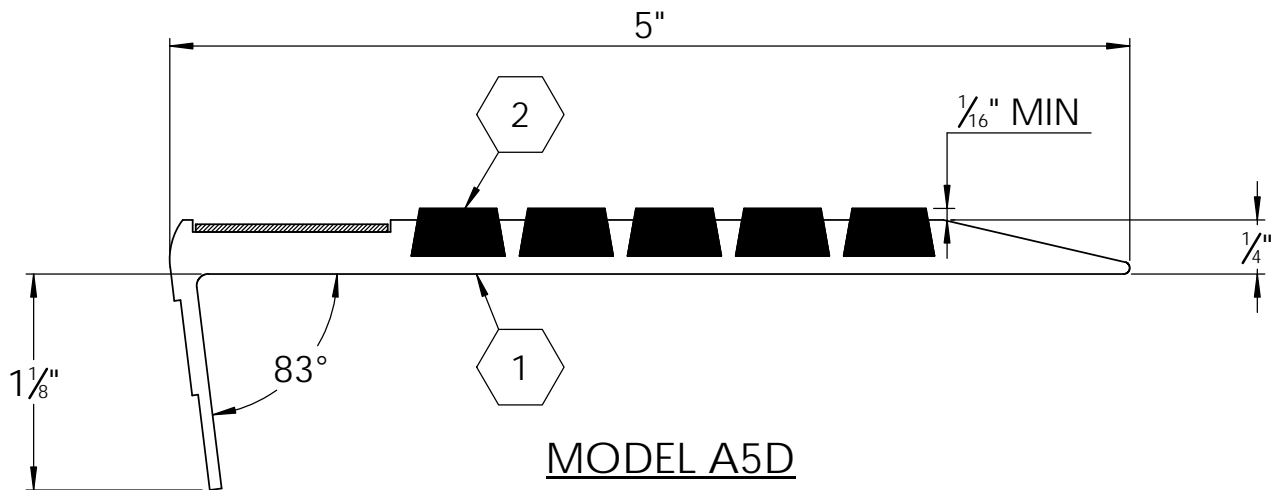

MODEL A5D

(RENOVATION RIBBED ABRASIVE BARS)

SPECIFICATIONS:

- ① **BASE:** EXTRUDED ALUMINUM ALLOY 6063 T-5
- ② **ABRASIVE:** ALUMINUM OXIDE SILICON CARBIDE GRANULES IN A UV PROTECTED, 2 PART EPOXY, LOCKED INTO EXTRUDED CHANNELS
- 3. **BASE FINISH:** MILL
- 4. **POURED CONCRETE STAIRS:** NOSING SHALL TERMINATE NO MORE THEN 3" FROM END OF STEPS
- 5. **CONCRETE FILLED STEEL PAN STAIRS:** NOSING SHALL BE FULL LENGTH OF STEPS, LESS 1/8" CLEARANCE
- 6. **COLOR:** BLACK (STANDARD), SAFETY YELLOW, GRAY, RED, BROWN, GREEN, BURGUNDY, BLUE, BUFF, LUMINESCENT

- 7. **LENGTH:** 12'0" MAXIMUM
- 8. COUNTER SUNK HOLES PRE-DRILLED FOR A #10 FASTENER SPACED 3" FROM ENDS AND APPROXIMATELY 12" TO 15" O.C.
- 9. UL 1994 LISTED: COMBINED WIDTH OF PHOTO-LUMINESCENT MATERIAL SHALL NOT BE LESS THAN 1"

LENGTH	QTY	COLOR

PROJECT:			
ARCHITECT:			
CONTRACTOR:			
QTY:			
PART#:		BSTRM-A5D	
<p>9300 73rd Avenue North Brooklyn Park, MN 55428</p>		TITLE: Stair Tread, Renovation Alum, Bar Ribbed Abrasive Long Nose Angled, Drilled For Fastener 1" Photoluminescent Insert,	
NAME	DATE	SIZE	DWG. NO.
RELEASED	TR	10/1/21	Babcock STN BSTRM-A5D ShpDr
WEIGHT: 2 LB		SHEET 1 OF 1	

PROPRIETARY AND CONFIDENTIAL: THE INFORMATION CONTAINED IN THIS DRAWING IS THE SOLE PROPERTY OF BABCOCK-DAVIS. ANY REPRODUCTION IN PART OR AS A WHOLE WITHOUT THE WRITTEN PERMISSION OF BABCOCK-DAVIS IS PROHIBITED.