

**SPECIFICATIONS:**

- ① **DOOR:** ALUMINUM, 1/4" SMOOTH PLATE, RECESSED, MILL FINISH WITH A LIVE LOAD OF 300 PSF WITH A MAXIMUM DEFLECTION OF L/160
  - ② **FRAME:** ALUMINUM, 1/4" EXTRUSION, RECESSED, EPOXY PAINT FINISH ON EXTERIOR SURFACES THAT COME IN CONTACT WITH CONCRETE
  - ③ **HINGES:** TYPE 316 STAINLESS STEEL
  - ④ **SLAM LATCH:** TYPE 316 STAINLESS STEEL WITH INSIDE LEVER HANDLE AND OUTSIDE REMOVABLE 5/16" SQUARE L HANDLE
  - ⑤ **COUNTER-BALANCE SPRING:** TYPE 17-7 STAINLESS STEEL SPRING ENCLOSED IN A TYPE 316 STAINLESS STEEL TELESCOPING TUBE
  - ⑥ **HOLD-OPEN ARM:** TYPE 316 STAINLESS STEEL WITH RED VINYL GRIP HANDLE
  - ⑦ **ANCHOR:** 4" CONCRETE ANCHOR STRAPS PROVIDED
  - ⑧ **TILE EXTRUSION:** ALUMINUM, RECESSED FOR 1/8" FLOOR COVERING
- FLOOR DOOR SIZE:**  
" (WIDTH) x " (LENGTH)
- CLEAR UNOBSTRUCTED OPENING:**  
" (WIDTH) x " (LENGTH)
- OPENING:**  
" (WIDTH) x " (LENGTH)

PROPRIETARY AND CONFIDENTIAL; THE INFORMATION CONTAINED IN THIS DRAWING IS THE SOLE PROPERTY OF BABCOCK DAVIS. ANY REPRODUCTION IN PART OR AS A WHOLE WITHOUT THE WRITTEN PERMISSION OF BABCOCK DAVIS IS PROHIBITED. THIS IS A GENERIC SHOP DRAWING AND MAY NOT BE AN ACTUAL REPRESENTATION OF THE FINAL PRODUCT.

PROJECT:			
ARCHITECT:			
CONTRACTOR:			
QTY:			
PART#:		<b>BFDRPA X DAL</b>	
 9300 73rd Avenue North Brooklyn Park, MN 55428		TITLE: Floor Door, Recessed Series, Dbl Dr, 316 SST Hdw, Alum, Mill, Pedestrian, Cast-In Anchors, Slam Latch Removbl L Hdl	
NAME	DATE	SIZE	DWG. NO.
DRAWN JE	04/18/11	A	BFDRPA_X_DAL
RELEASED DWO	04/18/11	WEIGHT: Varies	
			REV A
			SHEET 1 OF 2

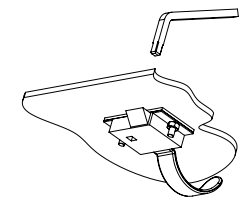
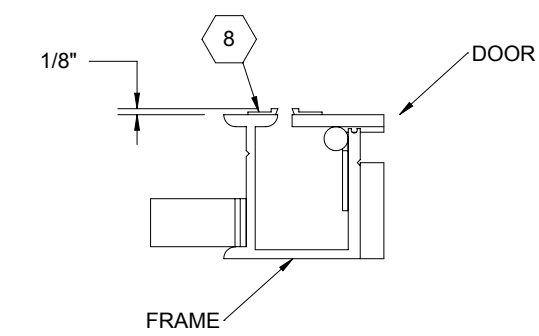
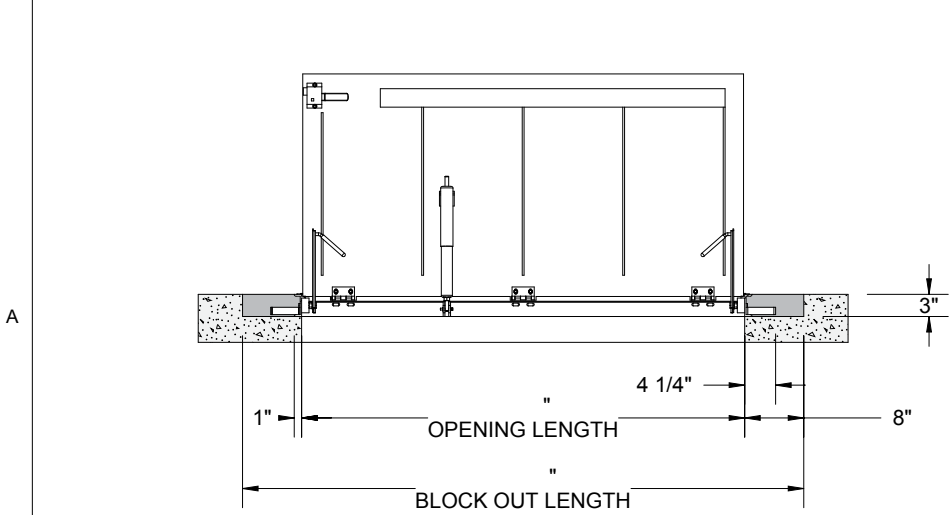
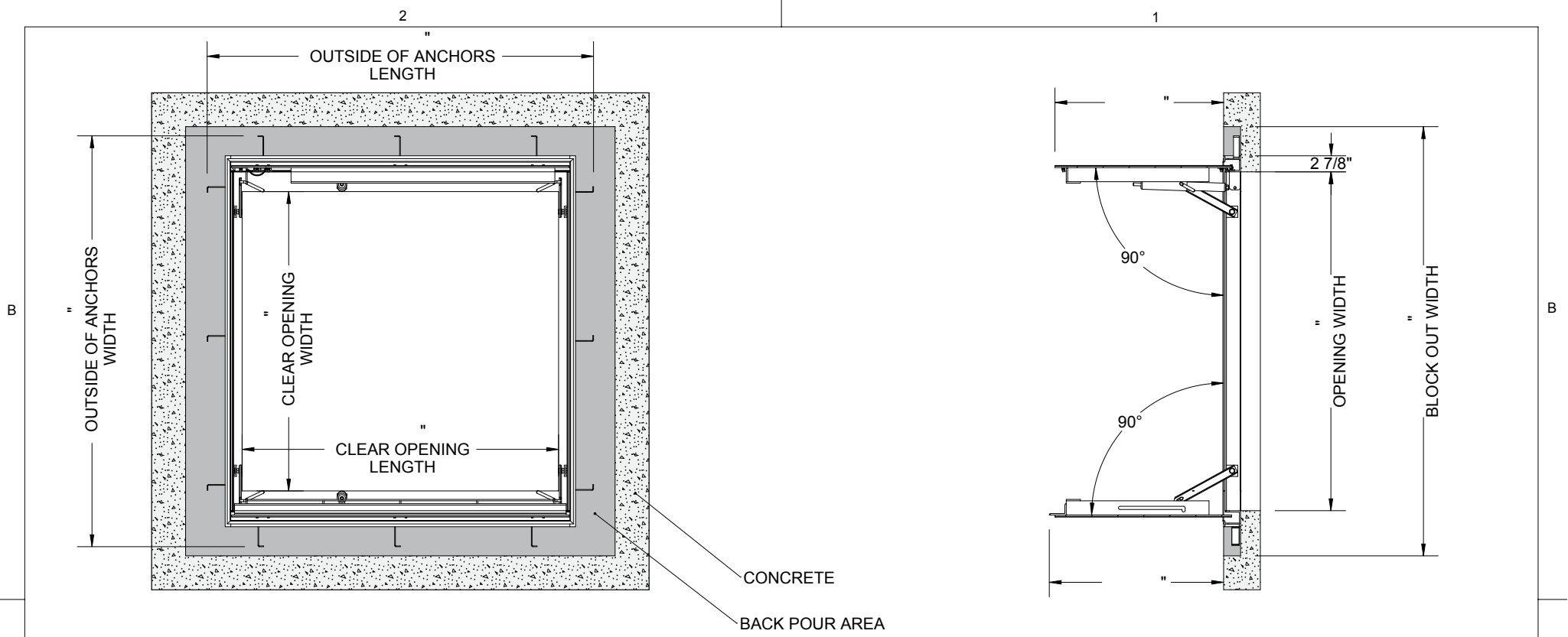

TILE EXTRUSION DETAIL

SLAM LATCH DETAIL

				<b>TITLE:</b> Floor Door, Recessed Series, Dbl Dr, 316 SST Hdw, Alum, Mill, Pedestrian, Cast-In Anchors, Slam Latch Removbl L Hdl	
9300 73rd Avenue North Brooklyn Park, MN 55428				<b>DWG. NO.</b> BFD RPA_X_DAL	
<b>DRAWN</b>	JE	04/18/11	SIZE A	<b>REV</b> A	
<b>RELEASED</b>	DWO	04/18/11	<b>WEIGHT:</b> Varies		<b>SHEET</b> 2 OF 2

PROPRIETARY AND CONFIDENTIAL; THE INFORMATION CONTAINED IN THIS DRAWING IS THE SOLE PROPERTY OF BABCOCK DAVIS. ANY REPRODUCTION IN PART OR AS A WHOLE WITHOUT THE WRITTEN PERMISSION OF BABCOCK DAVIS IS PROHIBITED. THIS IS A GENERIC SHOP DRAWING AND MAY NOT BE AN ACTUAL REPRESENTATION OF THE FINAL PRODUCT.