

For dry, interior installation only. Not intended for wet or exterior environments.

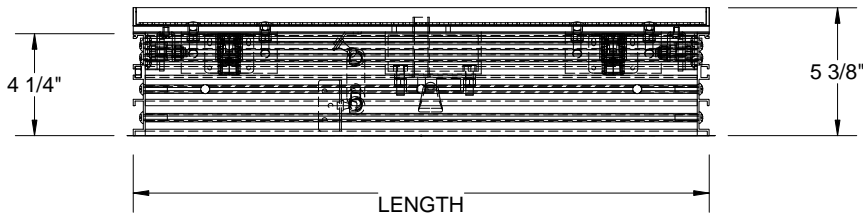
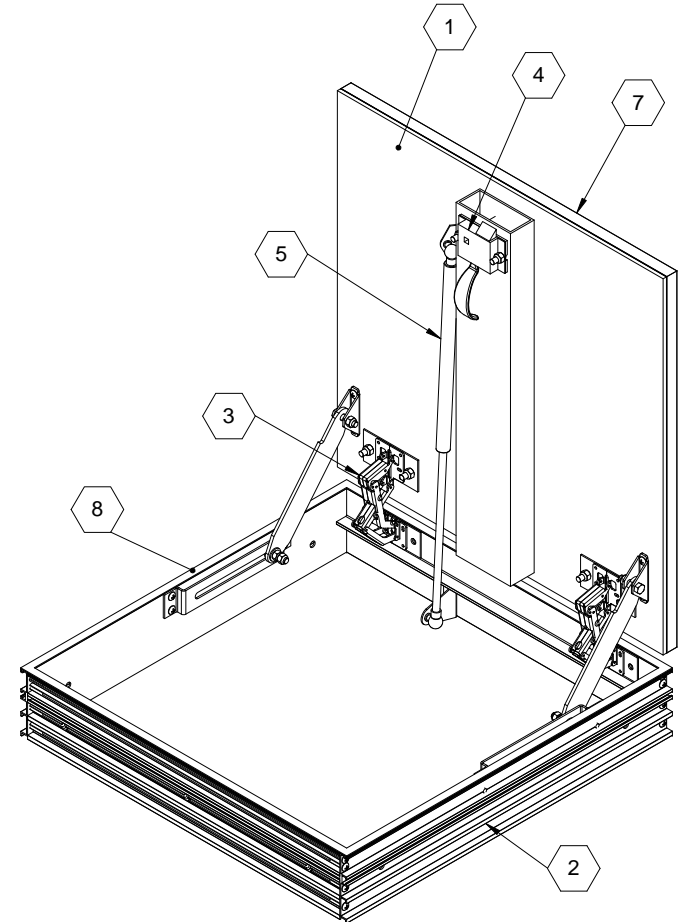

SPECIFICATIONS:

- ① **DOOR:** ALUMINUM, 1/4" SMOOTH PLATE, MILL FINISH WITH A LIVE LOAD OF 300 PSF WITH A MAXIMUM DEFLECTION OF L/160
- ② **FRAME:** ALUMINUM, F-2C EXTRUSION, EPOXY PAINT FINISH ON EXTERIOR SURFACES THAT COME IN CONTACT WITH CONCRETE
- ③ **HINGES:** CABINET STYLE LIFT HINGE, SPRING LOADED
- ④ **SLAM LATCH:** TYPE 316 STAINLESS STEEL WITH INSIDE LEVER HANDLE AND OUTSIDE REMOVABLE 5/16" SQUARE L HANDLE AND PLUG
- ⑤ **COUNTER-BALANCE SPRING:** DAMPENED GAS SPRING
- ⑥ **ANCHOR:** HOLES PROVIDED IN FRAME FOR BOLTING IN ON SITE

- ⑦ **TILE EXTURSION:** ALUMINUM EXTRUSION RECESSED 3/4" WITH EXPANDED METAL MESH BASE FOR CONCRETE, MESH IS REMOVABLE FOR WOOD OR RUBBER FILL
- ⑧ **GASKET:** EPDM, ON FRAME AROUND PERIMETER

FLOOR DOOR SIZE: (WIDTH) x (LENGTH)
 CLEAR UNOBSTRUCTED OPENING: (WIDTH) x (LENGTH)
 OPENING: (WIDTH) x (LENGTH)

PROPRIETARY AND CONFIDENTIAL: THE INFORMATION CONTAINED IN THIS DRAWING IS THE SOLE PROPERTY OF BABCOCK-DAVIS. ANY REPRODUCTION IN PART OR AS A WHOLE WITHOUT THE WRITTEN PERMISSION OF BABCOCK-DAVIS IS PROHIBITED. THIS SHOP DRAWING MAY NOT BE AN ACTUAL REPRESENTATION OF THE FINAL PRODUCT.

PROJECT:					
ARCHITECT:					
CONTRACTOR:					
QTY:					
PART#:					
 9300 73rd Avenue North Brooklyn Park, MN 55428		TITLE: Floor Door, Non-Drainable, Sngl Dr, Corrosion Resistant Hdw, Alum, Mill, Pedestrian, Bolt-In Anchors, Slam Latch Removbl L Hdl, 1" Recessed Pan			
		NAME	DATE	SIZE	DWG. NO.
DRAWN	JPB	10-9-17	A	Babcock FD BFDPPA_X_SBL ShpDr	
RELEASED	TR	10-9-17	WEIGHT: 34 LB		SHEET 1 OF 1