

SPECIFICATIONS:

- ① **DOOR:** ALUMINUM, 1/4" DIAMOND PLATE, MILL FINISH WITH A LIVE LOAD OF 300 PSF WITH A MAXIMUM DEFLECTION OF L/1) 0
- ② **FRAME:** ALUMINUM, 1/4" EXTRUSION, ; F5MDF A 9F FINISH ON EXTERIOR SURFACES THAT COME IN CONTACT WITH CONCRETE
- ③ **HINGES:** TYPE 316 STAINLESS STEEL
- ④ **SLAM LATCH:** TYPE 316 STAINLESS STEEL WITH INSIDE LEVER HANDLE AND OUTSIDE REMOVABL 9 < 5 B 8 @
- ⑤ **COUNTER-BALANCE SPRING:** 9B 7 @ C G98 zTYPE 17-7 SGH CDF B ;
- ⑥ **HOLD-OPEN ARM:** TYPE 316 STAINLESS STEEL WITH RED VINYL GRIP HANDLE

- ① **DRAINAGE COUPLING:** 1-1/2"
- ④ **FLUSH TYPE PLUG SEAL:** TYPE 316 STAINLESS STEEL
- ① **GASKET:** EPDM AIR TIGHT GASKET
- ① **SAFETY GRATE:** ALUMINUM, 6" SERRATED RAILS WITH SAFETY ORANGE POWDER COAT, LIVE LOAD OF 300 PSF, SST HINGESLOCK AND INTEGRAL PADLOCK HASP

PROPRIETARY AND CONFIDENTIAL: THE INFORMATION CONTAINED IN THIS DRAWING IS THE SOLE PROPERTY OF NYSTROM. ANY REPRODUCTION IN PART OR AS A WHOLE WITHOUT THE WRITTEN PERMISSION OF NYSTROM IS PROHIBITED. THIS SHOP DRAWING MAY NOT BE AN ACTUAL REPRESENTATION OF THE FINAL PRODUCT.

PROJECT:					
ARCHITECT:					
CONTRACTOR:					
QTY:					
PART#:				
babcockdavis 9300 73rd Avenue North Minneapolis, MN 55428		TITLE: Floor Door, Drainable Series, Sngl Dr, 316 SST Hdw, Alum, Mill, Pedestrian, Cast-In, Slam Latch Removbl L Hdl, Safety Grate			
		NAME	DATE	SIZE	DWG. NO.
DRAWN	JPB	2-6-18	A	BFDDPA ' X' SFL-SGT ShpDr	A
RELEASED	TR	2-6-18	WEIGHT: 96 LB		SHEET 1 OF 2

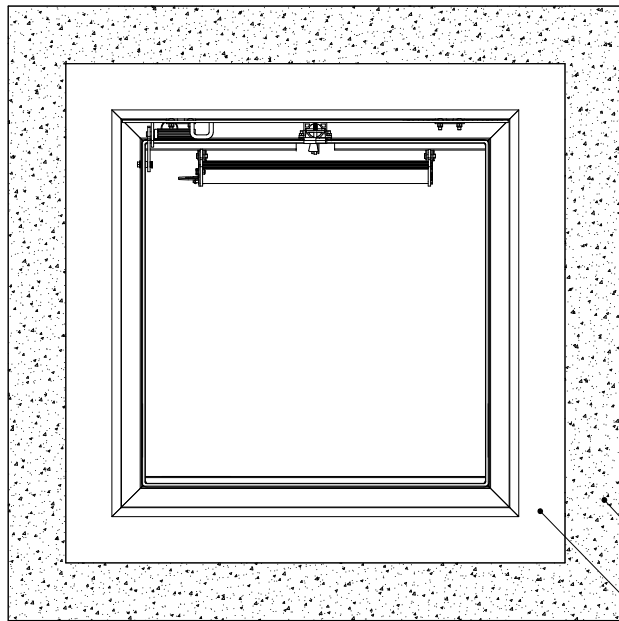

CONCRETE

BACK POUR AREA

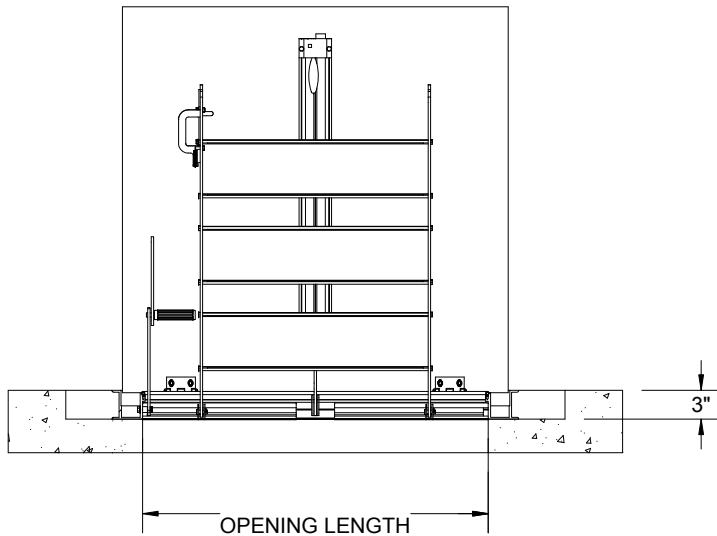
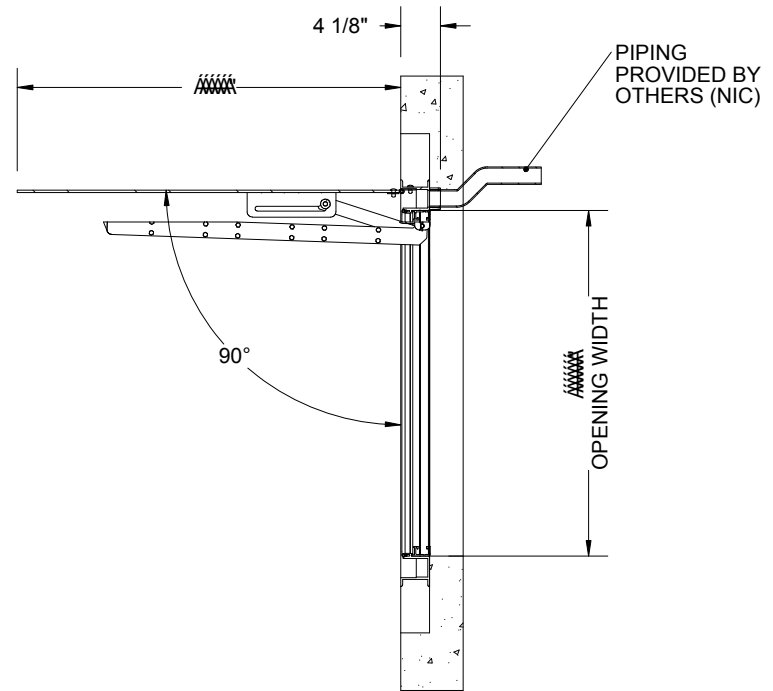

OPENING LENGTH

3"

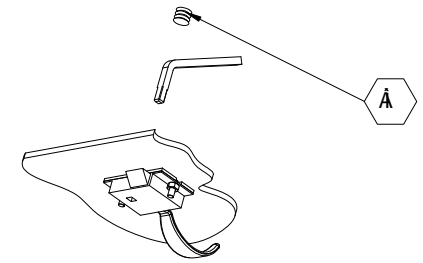

SLAM LATCH DETAIL

			TITLE: Floor Door, Drainable Series, 36" x 36" Ingl Dr, 316 SST Hdw, Alum, Mill, Pedestrian, Cast-In, Slam Latch Removbl L Hdl, Safety Grate		
9300 73rd Avenue North Minneapolis, MN 55428			SIZE A	DWG. NO. 18040FDDPA 'X' SFL-SGT ShpDr	REV A
DRAWN JPB	NAME TR	DATE 2-6-18	RELEASED	WEIGHT: 96 LB	SHEET 2 OF 2

PROPRIETARY AND CONFIDENTIAL: THE INFORMATION CONTAINED IN THIS DRAWING IS THE SOLE PROPERTY OF NYSTROM. ANY REPRODUCTION IN PART OR AS A WHOLE WITHOUT THE WRITTEN PERMISSION OF NYSTROM IS PROHIBITED. THIS SHOP DRAWING MAY NOT BE AN ACTUAL REPRESENTATION OF THE FINAL PRODUCT.