

DETAIL C
SCALE 1 : 8

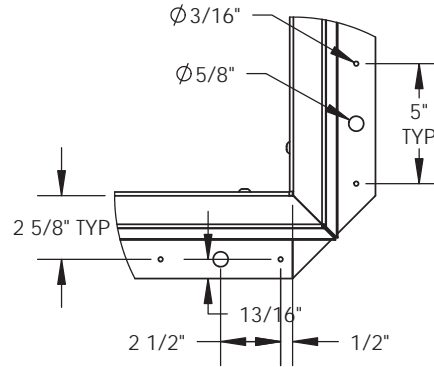

PULL TO RELEASE HOLD OPEN ARM.

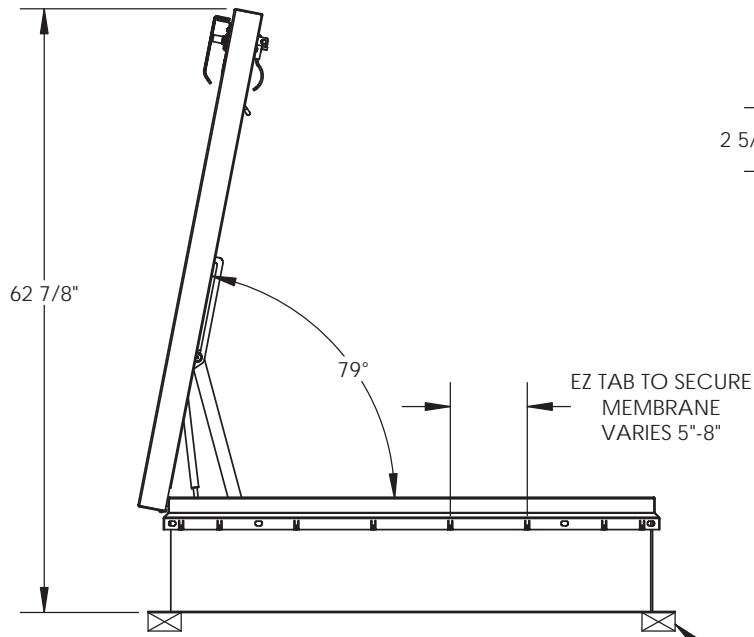

WOOD, CONCRETE, OTHER MATERIAL FOR MOUNTING BY OTHERS (NIC)

| | | | | | |
|---|----------------|---------------|---|------------------|----------------|
| | | | TITLE: BRHUA48X48S1T Roof Hatch Personnel II, 48x48, S Dr, Alum, Mill, Sngl Wall Curb | | |
| 9300 73rd Avenue North Brooklyn Park, MN 55428 | | | SIZE: A | DWG. NO.: BA4848 | REV: - |
| DRAWN: SGS | DATE: 04/01/15 | RELEASED: IMT | NAME: IMT | DATE: 04/01/15 | WEIGHT: 96 lbs |
| | | | | | SHEET 2 OF 2 |