

DETAIL C  
SCALE 1 : 8

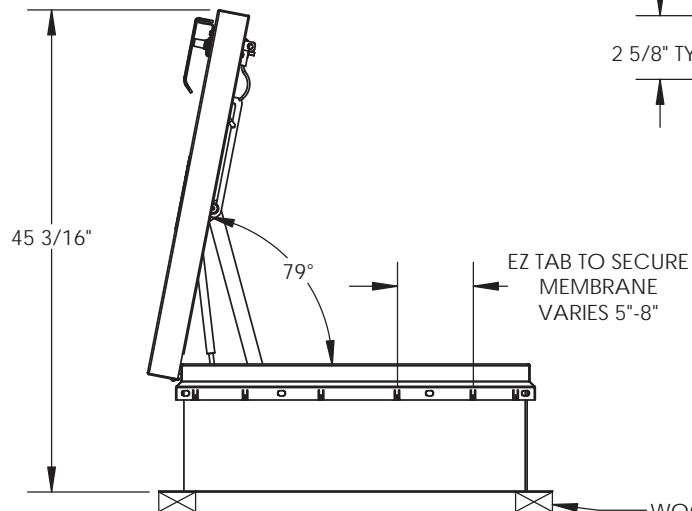
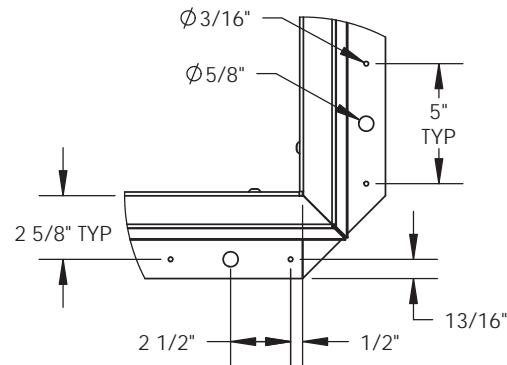

WOOD, CONCRETE, OTHER MATERIAL FOR MOUNTING BY OTHERS (NIC)

|   |                |               |   |                 |        |
|---|----------------|---------------|---|-----------------|--------|
|   |                |               | TITLE: BRHUA30X54S1T Roof Hatch<br>Personnel II, 30x54, S Dr,<br>Alum, Mill, Sngl Wall Curb |                 |        |
| 9300 73rd Avenue North<br>Brooklyn Park, MN 55428 |                |               | SIZE: A   | DWG. NO. BA3054 | REV: - |
| DRAWN: SGS  | DATE: 04/01/15 | RELEASED: IMT | WEIGHT: 79.5 lbs  | SHEET 2 OF 2    |        |