

Fire-Rated Security Access Doors

Model(s): BSP/BST/BSW

GENERAL DESCRIPTION



Access Doors are designed and built for years of convenient and easy access to mechanical areas in commercial buildings. The following are general instructions for installing, operating and maintaining Fire-Rated Access Doors.

Introduction + Safety

Please read the complete instructions carefully before beginning any work. To ensure proper installation and performance of the product the following actions must be completed by the installing contractor. Failure to do so will affect product warranty.

GENERAL SAFETY PRECAUTIONS Improper selection, installation, or use can cause personal injury or property damage. It is solely the responsibility of the user, through its own analysis to select products suitable for their specific application requirements, ensure they are properly maintained, and limit their use to its intended purpose. Follow proper local, state and federal regulations for proper installation and operation requirements.

Transportation + Storage

- Inspect all shipments and materials for missing or damaged components and hardware.
- Material must be stored in a clean, dry location.

Preparation

1. A framed opening is required.
2. The studs need to be wrapped with 5/8" Type X (fire-retardant) gypsum board.
3. Opening dimensions should be 1/4" larger than catalog size of door, after wrapping studs. Example: 12" x 12" door, opening should be 12-1/4" x 12-1/4".
4. **A notched-out area is required for the lock bolt cover.**

INSTALLATION

Wood and Steel Framing ¹

1. Place door in opening and mark location of attachment on studding using holes in latch and hinge side door frame as guides.
2. Remove door and drill pilot holes through studs at points marked for attachment hole.
3. Place door into position and fasten to wall as follows:
4. For panels with a drywall bead flange (SW), screws should be fastened at a maximum of 3” from the ends and 18” on center maximum through the flange face **in addition** to the holes located on the inside of the frame.
5. Check door for freedom of movement. If it binds, shim to remove any racking of frame at attachment points.
6. Install springs per reference table. Self-closure of door is required for UL fire rating. Neglecting to install springs will void the fire-rating.

MASONRY WALL ¹

Tools Needed	Supplies Needed
Drill Bit and Drill	Flat-head steel machine screws with expansion shield or flathead concrete fastener

Installation

1. Place door in opening and mark location of attachments using holes in latch and hinge sides of door frame as guides.
2. If using expansion shields, remove door and install-shields in wall at points marked.
3. Place door into position and fasten with flat-head steel machine screws or concrete fastener.
4. Check door for freedom of movement. If it binds, shim to remove any racking of frame at attachment points.
5. Install springs per reference table 1. Self-closure of door is required for UL fire-rating. Neglecting to install springs will void the fire-rating (Figure 3).

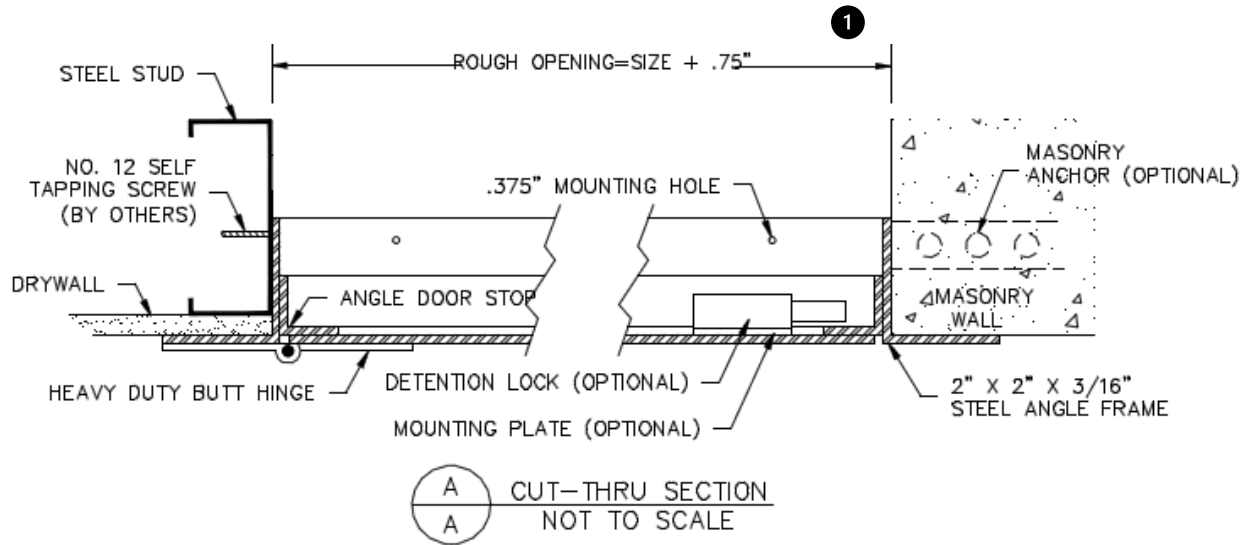

Door Size	Spring Location		
	A	B	C
8 X 8	1	-	-
10 X 10	1	-	-
12 X 12	1	-	-
12 X 24	-	1	1
14 X 14	1	-	-
16 X 16	-	1	1
18 X 18	-	1	1
18 X 24	-	2	1
20 X 30	-	2	2
22 X 22	-	2	1
24 X 24	-	2	2

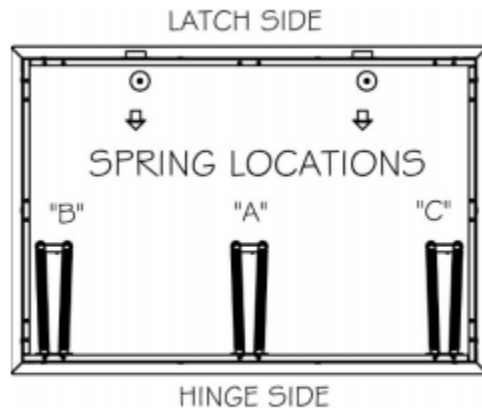

Figure 3

Table 1. Quantity and Location of Springs by Door Size

OPERATION

Access doors are designed and built for years of dependable wall and ceiling access. Our access doors come standard with a paintable powder coat finish.

MAINTENANCE

- Access doors should be manually operated once a year to check performance.
- Lubricate moving parts such as hinges and latches with a silicone spray lube as required to maintain a smooth opening and closing of the door. Do not overlubricate. Do not use lubricating that can attract dust and grit.
- Non-moving parts can be cleaned with a mild soap or dishwashing detergent and water solution.

QUESTIONS?

For more information on installation, repair or replacement, please visit www.babcockdavis.com.