

Smoke Vents

Model(s): BSVT

GENERAL DESCRIPTION



Smoke vents are designed to open automatically to provide emergency smoke and heat ventilation. Prompt venting in case of fire is essential for the safe evacuation of occupants and for effective fire-fighting conditions within a building. The smoke vent is not intended for use as general-purpose building ventilation devices. International Building Code requires smoke venting in a variety of applications including Factory and Storage Facilities, Stages and Platforms. The following are general instructions for installing, operating, and maintaining smoke vent products. These are recommended general guidelines only. Locally accepted roofing and sealing practices and procedures should be followed to ensure the ultimate weather-ability of vents installed into various types of roofing systems.

GENERAL SAFETY PRECAUTIONS Improper selection, installation, or use can cause personal injury or property damage. It is solely the responsibility of the user, through its own analysis to select products suitable for their specific application requirements, ensure they are properly maintained, and limit their use to its intended purpose. Follow proper local, state and federal regulations for proper installation and operation requirements.

Introduction + Safety

Please read the complete instructions carefully before beginning any work. To ensure proper installation and performance of the Smoke Vent the following actions must be completed by the installing contractor. Failure to do so will affect the product warranty.

Transportation + Storage

- Inspect all shipments and materials for missing or damaged components and hardware.
- Material must be stored in a clean, dry location.

INSTALLATION

Ensure that the roof mounting surface is level to avoid twisting of the smoke vent base. It is essential that the vents are installed level and square for the door to make a proper seal. Place the smoke vent over the existing opening in the roof that has been prepared with appropriate roofing membrane, if applicable.

The roof's rough opening dimensions are equal to the vent dimensions as measure from the inside curb to inside curb. For example, a 48 inch by 96 inch smoke vent will have a roof rough opening of 48 inches by 96 inches.

1. The smoke vent single wall curb flange comes with two (2) types of mounting holes to accommodate multiple fastening methods practiced and accepted at a local level.
 - Mark the pre-drilled 5/8 inch diameter holes from the mounting flange through to the roof deck or a concrete curb. Drill roof deck or concrete curb for installation of anchors or other fasteners (provided by others). Bolt or otherwise fasten roof hatch curb flange to roof deck using 3/8 inch or 1/2 inch bolts with washers.
 - Factory Mutual (FM4430) labeled vents must use one of these methods.

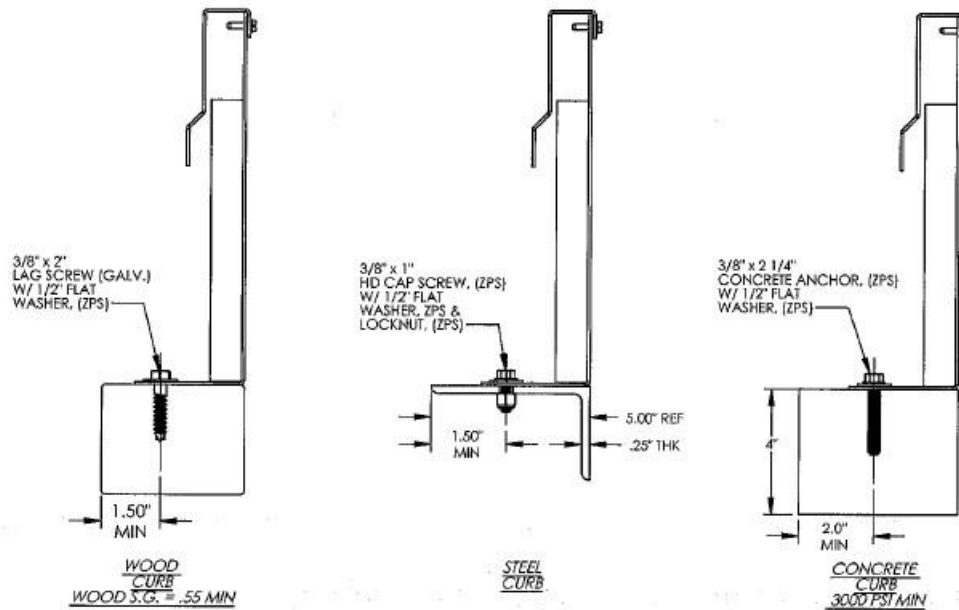
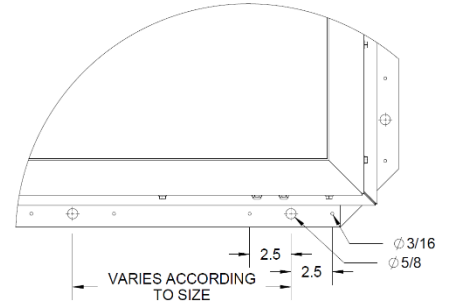

- Mark the pre-drilled 3/16 inch diameter holes from the mounting flange through to the roof deck, typically into a built-up wood fame curb. Fasten roof hatch curb flange to framing using roofing nailers and/or screws, recommended size 3/16 inch by 1-1/4 inch long.

Metal Decking Installation

Mechanical fasteners (screws, power, or pneumatically driven fasteners, etc.) are recognized as viable anchoring methods, provided the type and spacing of the fastener satisfies the design criteria, with fasteners providing a minimum 5/16 inch (8mm) diameter bearing surface (fastener head size). The strength of mechanically fastened connections is dependent upon both deck and support thickness.

In accordance with the ANSI RD-2010 Standard for Steel Roof Deck, section 3.4 Accessory Attachment,

- Structural accessories shall be attached to supporting structure or deck as required for transfer of forces, but not to exceed 12 inches (300 mm) on center. Nonstructural accessories shall be attached to supporting structure or deck as required for serviceability, but not to exceed 24 inches (600 mm) on center.
- Mechanical fasteners or welds shall be permitted for accessory attachment.

For Curb Mount Installation

Prepare the curb using standard acceptable weatherproofing methods (i.e. butyl tape, sealant, etc.). Place the smoke vent on the curb. Fasten the smoke vent to the curb using pan-head fasteners that will penetrate the curb a minimum of 3/4 inch. Install fasteners every 16 inches along the sides and ends of the smoke vent.

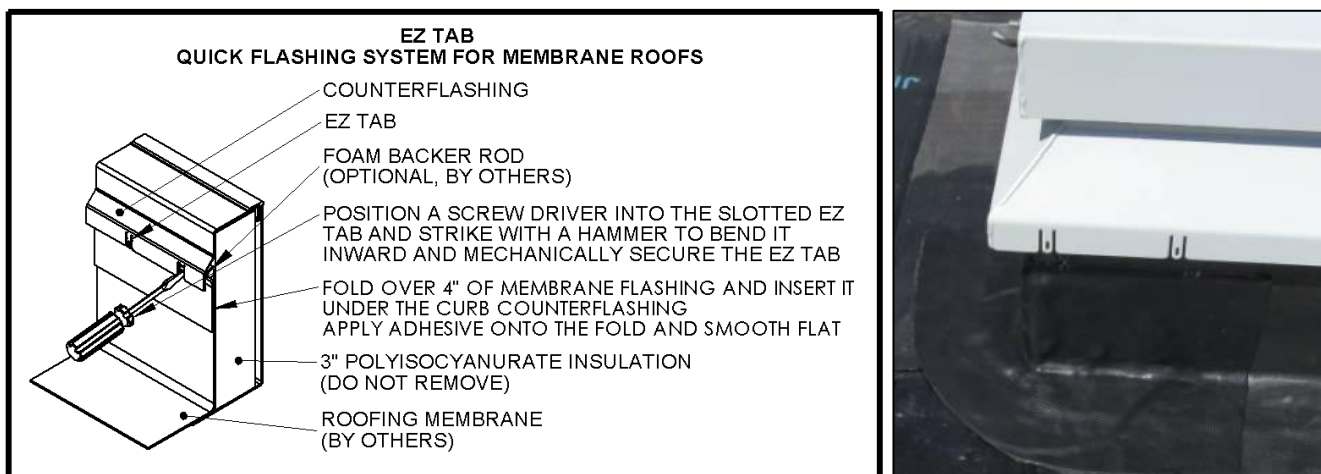

Install roofing material up to and around the roof curb, up under the counterflashing, using appropriate roofing material and locally accepted processes. Do not remove curb insulation. Lay membrane flashing up onto curb insulation. Press up under counterflashing using foam backer rod (by others). Apply adhesive to fully secure membrane in position. Ensure all joints are fully sealed to provide a weather tight seal. Bend EZ tabs to mechanically secure, using a screwdriver or similar tool.

Conduct an acceptance performance test and inspection of all smoke vents immediately following installation to establish that all operating mechanisms function properly.

OPERATION

Vents are designed and built for many years of dependable service. The assembly includes a curb and cover with a continuous extruded EPDM gasket that creates a weather resistant seal. *Warning: If the interior of smoke vents is field painted, all component parts must be masked. Critical component parts include spring/dampers, latches, fusible links, and any labels. Painted component parts may damage the smoke vents and will void the warranty.*

Field Testing

If required, test for proper operation after installation by one or more of the following:

1. Melt fusible link located inside the smoke vent using a hand-held propane tank torch. Replace fusible link from automatic latching mechanism, as shown below.
2. Pull internal or external manual pull handle with red vinyl grip, then close smoke vents.
3. If applicable, open vents using an electrical signal from the fire alarm, push button controller or other applicable electrical means.

OPENING SMOKE VENTS

Manual Operation

Smoke vents are designed to open manually via pull handles located on the exterior and interior of the smoke vent. The internal pull cable comes with 10 feet of 1/16 inch diameter aircraft cable. If required, additional cable can be ordered to extend and rig down to floor level.

Emergency Operation

Smoke vents are designed to open thermally when a UL 33 listed and labeled fusible link melts at its temperature rating (165°F, 212°F, 280°F, 350°F, 360°F, 370°F, 386°F, 450°F) in the event of an emergency fire. Fusible links are easily accessed from the roof for replacement.

TO REPLACE THE FUSIBLE LINK:

1. Back off the nut (1) all the way to remove tension from the spring.
2. Remove nut (2) and washer.
3. Remove screw (3), nut and washer.
4. Replace link, ensuring the proper lap joint orientation at the top.
5. Install screws (3), nut, and washer.
6. Replace nut (2) and washer leaving a 1/16 inch gap so the link is free to pivot.
7. Tighten down nut (1).

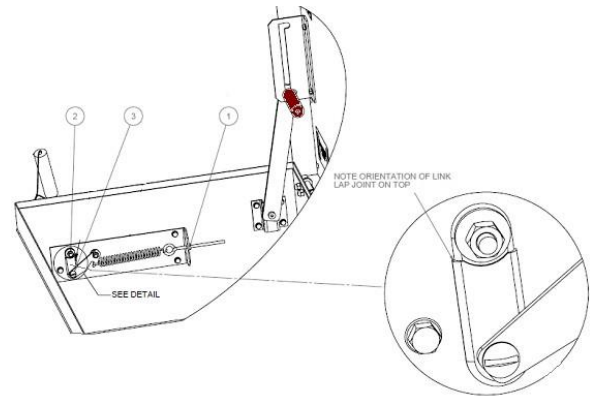

Electrical Opening

An optional Belimo actuator allows smoke vents to open electrically when a low voltage (24VDC/AC) or High Voltage (110VAC/220VAC) signal is sent to a UL listed rotary actuator to open vents in coordination with a fire alarm or sprinkler system.

CLOSING SMOKE VENTS

Smoke vent covers close manually from the exterior roof top level. Pull the red vinyl grip handle forward to *disengage* hold open arm from the slotted lock bracket. Safely close the cover and ensure latch engagement. It may require two people to close the door, due to the spring force. Smoke vent covers closed manually from the exterior roof top level. The closing procedure may require a couple people to close and securely latch the smoke vent doors.

Caution: Follow all OSHA fall protection safety requirements regarding fall protection (ie. OSHA 1926.500 regarding safety harnesses, tie-off points, etc.) It may be necessary to stand on top of the smoke vent door where the latch is centrally located and use one's body weight to force the doors into the fully latched position.

MAINTENANCE

Plan and schedule

Smoke Vents have a manual release device to allow direct activation to facilitate inspection, maintenance, and replacement of components, such as fusible links.

Vents should be manually operated in accordance with local fire safety precautions. At a minimum, the vents should be operated annually to check proper component performance.

Fusible link inspection

- Inspect fusible links at least annually for evidence of any corrosion, stress/strain or build-up of particulate matter.
- Fusible links that have been painted must be replaced as soon as the condition is observed.
- Fusible links coated with paper dust, fiberglass hairs or similar particulate matter should be cleaned. If cleaning with air pressure does not remove such matter, replace the links or contact either the Authority Having Jurisdiction or the fusible link manufacturer for guidance.

Cleaning recommendations

- Fusible links coated with paper dust, fiberglass hairs or similar particulate matter should be cleaned. If cleaning with air pressure does not remove such matter, replace the links, or contact either the Authority Having Jurisdiction or Babcock-Davis for assistance.
- Non-moving parts can be cleaned with a mild soap or dishwashing detergent and water solution.
- Gaskets can be cleaned with a clean, damp, lint-free cloth. *Do not apply mineral oils, vinyl dressings, or other lubricants to the gasket as they can cause the gasket to break down over time.*

SPARE PARTS AND SUPPLY LIST

- **Latch:** Positive hold release mechanism designed to hold the covers closed. Manually released by interior and exterior pull cables or thermally released by fusible melt out link.
 - (SV-KIT-ROTARYLATCH-S for single, SVX-KIT-ROTARYLATCH for double and quads)
- **Fusible Link:** Replaceable, melt out links. Select model # based on link temperature.
 - (SV-KIT-LINK-165, SV-KIT-LINK-280, SV-KIT-LINK-350, etc.)
- **Gas Spring/Damper:** Provides the force to automatically open covers against a 10psf snow load at a controlled speed.
- **Hold Open Arm:** Locking hold open arm automatically engages and locks when the door fully opens. Pull the red vinyl grip handle forward to disengage and safely close the door.

- (SV-KIT-HOA)

- **Gasket:** Adhesive backed continuous EPDM rubber gasket on cover.(SVT-KIT-GASKET)

Fusible link ambient temperature rating –

The fusible link should be specified with a temperature rating greater than the maximum ambient exposure temperature that will be seen at the installation. For example, an “ordinary” fusible link rated at 165 degrees F has a maximum ambient exposure temperature rating of 100 degrees F. If this fusible link is routinely exposed to ambient temperatures over 100 degrees F, it is liable to separate. Select a fusible link rated at 212 degrees F (or greater) for this type of application. See table below to find a fusible link temperature range compatible with an expected or measured ambient temperature. This is in accordance with UL guidelines.

Temperature classification	Temperature ratings		Maximum ambient temperature	
	Degrees F	(Degrees C)	Degrees F	(Degrees C)
Low	125 – 130	(51 – 54)	90	(32)
Ordinary	135 – 170	(57 – 77)	100	(38)
Intermediate	175 – 225	(79 – 107)	150	(66)
High	250 – 300	(121 – 149)	225	(107)
Extra high	325 – 375	(163 – 191)	300	(149)
Very extra high	400 – 475	(204 – 246)	375	(191)
Ultra high	500 – 575	(260 – 302)	475	(246)

Fusible link inspection – The following guidelines are recommended for facility managers or other end-users of smoke vent products.

- Inspect fusible links at least annually for evidence of corrosion, stress/strain, or build-up of particulate matter.
- Fusible links that have been painted must be replaced as soon as the condition is observed.
- Fusible links coated with paper dust, fiberglass hairs or similar particulate matter should be cleaned. If cleaning with air pressure does not remove such matter, replace the links, or contact either the Authority Having Jurisdiction or the fusible link manufacturer for guidance.

Questions? For more information on installation, repair, or replacement, please visit www.BabcockDavis.com or call 888.412.3726.