

## FIRE-RATED FLOOR DOORS

Model: BFDF

### GENERAL DESCRIPTION

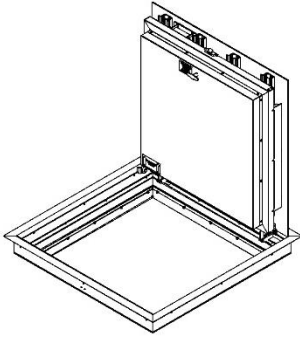

Floor Door products are designed and built for years of convenient access for personnel as well as equipment. The following are general instructions for installing, operating and maintaining fire rated floor door products. These are recommended general guidelines only. Locally accepted installation, mounting, and sealing procedures should be followed to ensure the ultimate weather-ability and structural integrity of the floors installed into various types of floor systems.

Fire rated floor doors are fire tested by Intertek and labeled Warnock Hersey per NFPA 288, Standard Methods of Fire Tests of Floor Fire Door Assemblies Installed Horizontally in Fire Resistance Rated Floor Systems

*Fire rated floor doors are intended for interior, dry environments.*

Do not store floor door outside. If storage is required, ensure the floor doors are properly covered and stored indoors.

**Fire rated floor doors are not intended for frequent egress.**

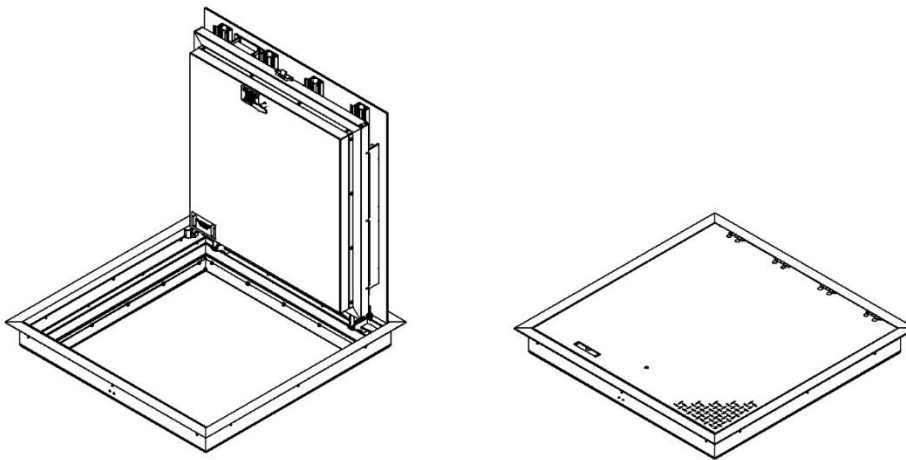

## Introduction + Safety

Please read the complete instructions carefully before beginning any work. To ensure proper installation and performance of the product, the following actions must be completed by the installing contractor. Failure to do so will affect product warranty.

## Transportation + Storage

- Inspect all shipments and materials for missing or damaged components and hardware.
- Material must be stored in a flat, clean, dry interior location.

## Preparation

- Locate the packing slip(s) and/or shop drawings.
- Verify that all products listed on the packing slip are included in the package.
- Check the products for damage. If products are damaged, report a freight claim immediately and leave the products in their packaging. If you sign for products without reporting damage you waive your right to a freight claim and will be

**GENERAL SAFETY PRECAUTIONS** Improper selection, installation, or use can cause personal injury or property damage. It is solely the responsibility of the user, through its own analysis to select products suitable for their specific application requirements, ensure they are properly maintained, and limit their use to its intended purpose. Follow proper local, state and federal regulations for proper installation and operation requirements.

responsible for their replacement cost.

- Read the instructions thoroughly before beginning installation.

## Tool List

- 1/2" Wrench or Socket (for anchor straps and spring keeper)
- 9/16" Wrench or Socket (for mounting door)
- Level
- Tape Measure
- Drill (Bolt-In Installation)
- Drill Bits:
  - 3/8" Masonry (for concrete openings)
  - 3/8" Regular (for wood openings)
- Shims
- Prybar

## Pre-Installation:

Please read the complete instructions carefully before beginning any work.

*Special care is required when handling and installing floor doors. Please make sure that all framework and doors are supported during transport and installation to insure against bending or racking of the floor door.*

Please inspect and set aside parts for later installation

- Slam latch keys
- Keeper extensions
- Plug for keyhole

## Storage

- Floor doors are shipped with the intent for installation within 30 days.
- If storage is required, ensure the floor doors are stored flat, covered and indoors.
- If stored outside, the floor door frames can expand and contract causing the protective coating to crack and chip.
- If the units are stored outside and the result is cracked primer, a primer coat must be reapplied before the unit is cast-in concrete. *Scrape and clean the affected surface and apply Rust-Oleum prior to installation.*

## Set Up/Unpack

*Warning: Floor Door covers are spring loaded. Ensure proper orientation prior to releasing slam latch. Do not release latch in upside down position.*

- Orient the floor door in an upright position as shown. This is the correct position to handle the floor door.
- Cut plastic tie wrap and remove envelope.

*Open in this position*

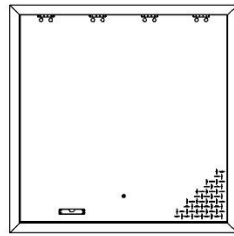

*Do not open in this position*

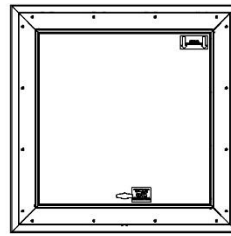

## INSTALLATION

### Cast-In Place Installation

1. Attach anchor straps
  - a. Floor doors for concrete pour applications are provided with 1"x4"x1/8" masonry anchors as shown. Anchors will need to be bolted on prior to install.
2. Square the frame
  - a. It is vital that the frame remains square and level during the concrete pour.
3. Set the frame in the opening
  - a. Secure the floor door into the desired area with welding, bolting or other anchorage, making sure not to interfere with the operation of the hatch.
4. Protect exposed aluminum from cement
  - a. To ensure a good quality installation and prevent staining, alkaline building materials such as cement should be removed quickly from aluminum surfaces.

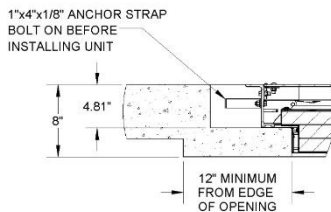

*2-hr cast in detail*

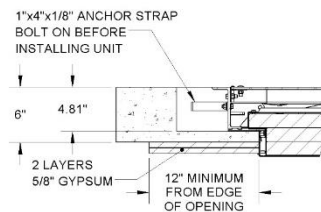

*2-hr alt cast in detail*

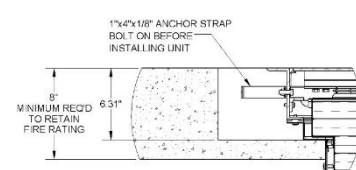

*3-hr cast-in detail\**

*\*3-hour rating available on Diamond Tread and 1/8" Pan Doors only.*

5. Set concrete

- a. Reference the options below and pour concrete to the top edge of the frame, leveling to finish flush with the top flange of the floor door. Allow to cure for seven days prior to opening the floor door. Opening the unit prior may crack the concrete.
- b. After the seven days for concrete curing, open the door(s) and inspect the unit for excess concrete that may have seeped or fallen into the hinges, or latch. *(The doors will be heavy until the springs are engaged; opening will require two people.)* It is important to note that springs will be disengaged on doors with more than two springs. Remove any concrete to ensure smooth operation.

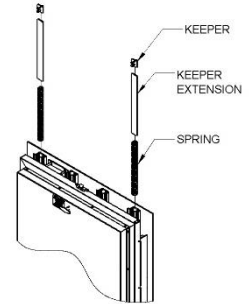

Figure 1

6. Engage Springs

- a. Manually open the door to the 90-degree position. The hold open arm, will automatically hold the door open.
- b. While in the 90-degree position the spring should settle on the plate at the bottom of the housing.
- c. Slide in the keeper extension until it rests on the spring. *(Figure 1)*
- d. Slide the spring keeper down until it touches the top of the spring keeper extension. Using a ½-inch wrench tighten the two hex head screws.
- e. Disengage the hold open arm to test the closing and opening operation. If the door does not close fully, slide the keeper back away from the keeper extension and retighten.

7. Adjust Spring (optional)

*Note: Spring position is factory set. Adjust only if field conditions require more or less spring force.*

- a. Open the door to the 90-degree position, the hold open arm will automatically hold the door open.
- b. First, disengage the spring by loosening the two hex head screws in the spring keeper. *(Figure 2)*

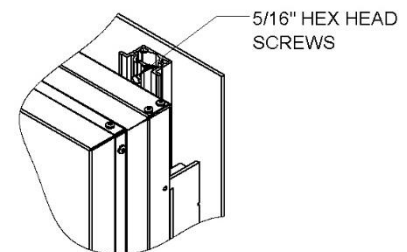
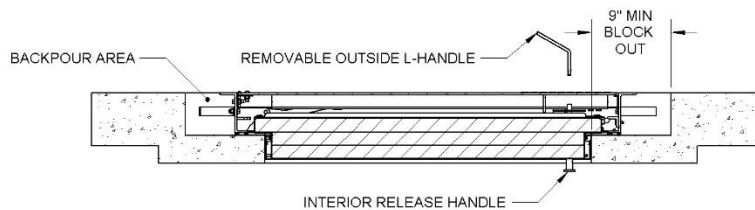
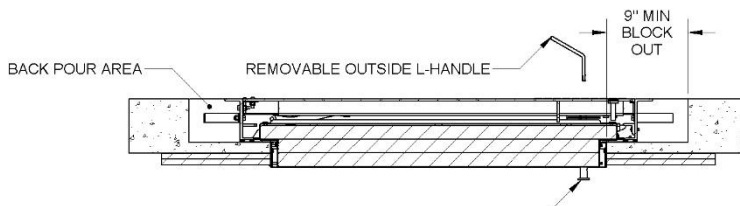

Figure 2

- c. Slide the keeper down toward the keeper extension to increase the force, or away from the spring to decrease the force, and re-tighten the hex head screws.
- d. Disengage the hold open arm to test the closing and opening operation.



*2-hr cast-in section*



*2-hr alt cast-in section*

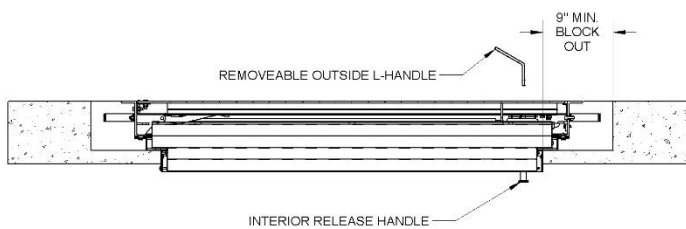

*3-hr cast-in section\**

*\*3-hour rating available on Diamond Tread and 1/8" Pan Doors only.*

## Bolt-In Place Installation

**NOTE:** Frames are pre-drilled with 3/8" diameter holes as shown in below. The bolt holes have clearance holes for 3/8-inch hardware. **All mounting hardware is provided by others.**

The flange on the frames will set on top of the flooring and the frame will slide into the opening.

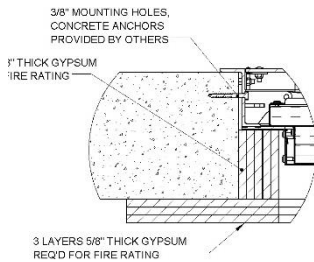

Figure 1

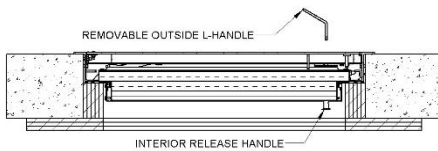

Figure 2

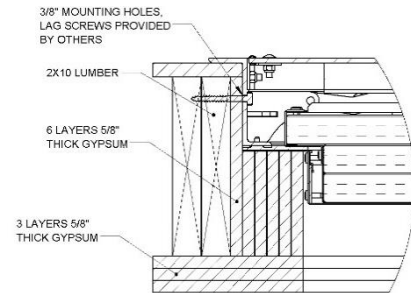

Figure 3

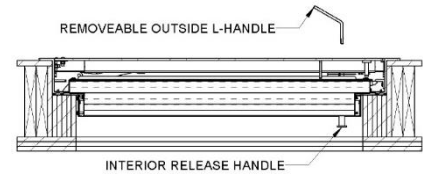

Figure 4

1. Mark Drill Hole Locations
  - a. Set the door into the desired opening area. The hinge side frame should make connection with the wall, this connection will add the necessary brace for the frame. Shim as necessary to square and level.
  - b. Mark where fastener holes are located on the mounting surface.
2. Drill holes in Mounting Surface
  - a. Remove the floor door and drill 3/8" diameter holes into the mounting surface at the marked locations.
3. Secure Floor Door to Mounting Surface
  - a. With two or more people, set the floor door in place and secure to the mounting surface with bolts (For existing concrete openings, 3/8-inch anchor bolts are recommended (Figure 1 & 2). For existing wood openings 3/8-inch lag bolts are recommended) (Figure 3 & 4). Secure Hinge side frame first.

*Note: Doors with more than two springs per door will be shipped with the springs loose within the housing. These springs must be secured in place before operating the door.*

#### 4. Engage Springs

- a. Manually open the door to the 90-degree position. The hold open arm, will automatically hold the door open.
- b. While in the 90-degree position the spring should settle on the plate at the bottom of the housing.
- c. Slide in the keeper extension until it rests on the spring.  
(Figure 1)
- d. Slide the spring keeper down until it touches the top of the spring keeper extension. Using a ½-inch wrench tighten the two hex head screws.
- e. Disengage the hold open arm to test the closing and opening operation. If the door does not close fully, slide the keeper back away from the keeper extension and retighten.

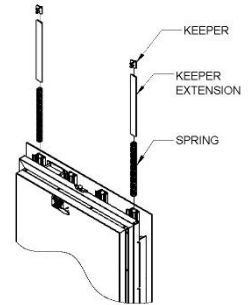

Figure 1

#### 5. Adjust Spring (optional)

*Note: Spring position is factory set. Adjust only if field conditions require more or less spring force.*

- a. Open the door to the 90-degree position, the hold open arm will automatically hold the door open.
- b. First, disengage the spring by loosening the two hex head screws in the spring keeper. (Figure 2)
- c. Slide the keeper down toward the keeper extension to increase the force, or away from the spring to decrease the force, and re-tighten the hex head screws.
- d. Disengage the hold open arm to test the closing and opening operation.

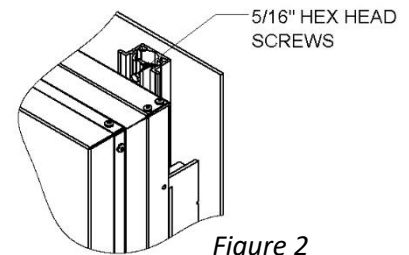

Figure 2



## 1/8" and 1" Pan Door Installation

Follow the installation guidelines for Cast-In Place and Bolt-In Place installation. Install flooring material following the flooring manufacturers recommendations.

For 1" Pan Doors (*Figure 2*), spring force is calculated for 1" infill of concrete. If less concrete or a lighter material is used, reduce spring force using the instructions on Page 8.

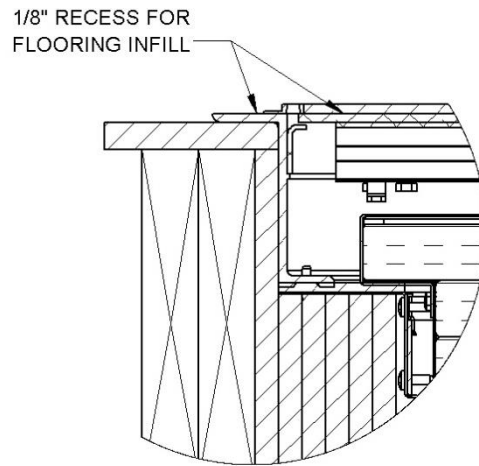

Figure 1

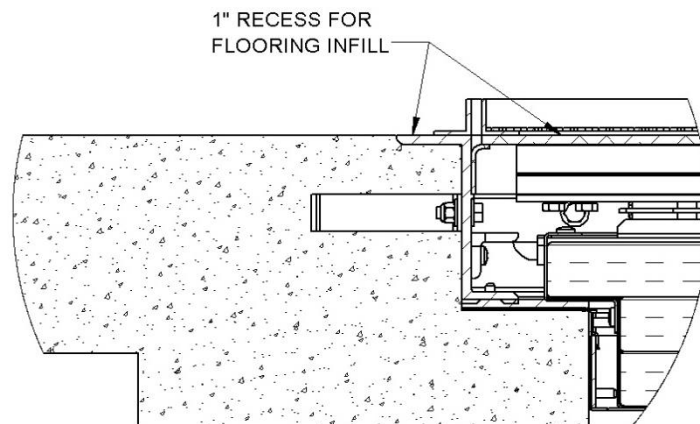

Figure 2

## OPERATION

Floor doors are designed and built for years of dependable access. All floor doors come standard with stainless steel hardware components. The basic components for door operation include turn handle latches, compression springs, stainless steel hinges and a locking hold open arm as detailed:

1. Latch: Zinc-plated steel slam latch with interior rotating handle, and exterior L-handle key
2. Spring: Compression springs to ensure ease of opening and closing during use.
3. Hinge: Stainless Steel hinges
4. Hold Open Arm: Locking hold open arm automatically engages and locks when the door fully opens. The hold open arm must be engaged in the locked position to ensure that the door does not close unintentionally. Pull the handle to unlock and safely close the door.
5. Optional Self-Closing Mechanism: Integrated in hold open arm assembly. (Figure 1)

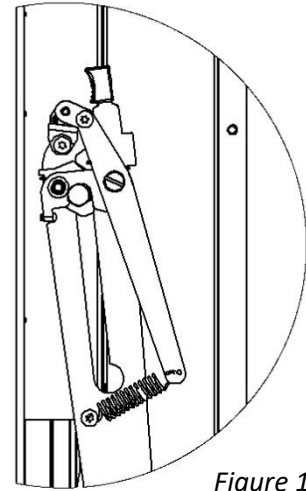

Figure 1

### Opening Fully Installed Door

Fire rated floor doors are not intended for frequent egress.

To open the floor door cover, use the slam latch L-handle key and rotate the slam latch. The cover will un-latch and the spring will begin to lift the door. Use the lift handles to fully pull open the door. The hold open arm engages and locks the cover in the 90-degree open position.

### Closing Fully Installed Door

To close the floor door cover, disengage the hold open arm and let door begin to close. Slam the door slightly to ensure proper latch engagement.

*Note: Units larger than 36" x 36" may be heavy and require more than one person to safely operate.*

## MAINTENANCE

- Floor doors should be manually operated at minimum twice per year to check performance.
- Lubricate moving parts such as hinges, and latches with a food grade grease or silicone spray lube as required to maintain a smooth opening and closing of the door. Do not over grease. Do not use regular lubricating oil as it can attract dust and grit.
- Non-moving parts should be cleaned with a mild soap or dishwashing detergent and water solution.
- Gaskets should be cleaned with a damp, lint-free cloth. Do not apply mineral oils, vinyl dressings, or other lubricants to the gasket as they many cause the gasket to break down over time.
- If floor doors are installed in corrosive environments such as environments exposed to saltwater or hydrogen chloride, the stainless-steel hardware must be coated with a custom finish and the springs should be lubricated on a strict three to six-month schedule.
- Do not allow unit to get wet. It may affect fire performance.

#	Part Number	Description
1	FD-KIT-KEY	Latch Key
2	FD-KIT-SLAMLATCH2-FDF	Single Point Slam Latch, 2-Hour Rating
	FD-KIT-SLAMLATCH3-FDF	Single Point Slam Latch, 3-Hour Rating
3	FD-KIT-2PTLATCH2-FDF	Two Point Slam Latch, 2-Hour Rating
	FD-KIT-2PTLATCH3-FDF	Two Point Slam Latch, 3-Hour Rating
4	FD-KIT-HINGE-FDF	Hinge
5	FD-KIT-SPRING40-FDF	Spring, 40 LB
6	FD-KIT-SPRING80-FDF	Spring, 80 LB
7	FD-KIT-PLUG	Latch Plug
8	FD-KIT-HOA-FDF	Hold Open Arm
9	FD-KIT-HOA-SCL-FDF	Self-Closing Hold Open Arm, Left Side
	FD-KIT-HOA-SCR-FDF	Self-Closing Hold Open Arm, Right Side
10	FD-KIT-LIFTHANDLE	Lift Handle
11	FD-KIT-SPRINGLINK-FDF	Spring Link
12	FD-KIT-SPRINGSTOP18	Spring Stop Keeper
13	FD-KIT-DOORCATCH-FDF	Door Catch

## Replacement Parts

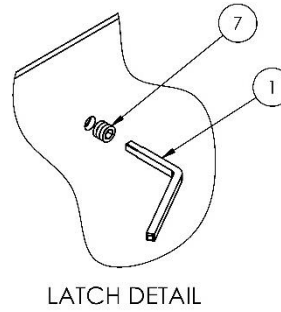
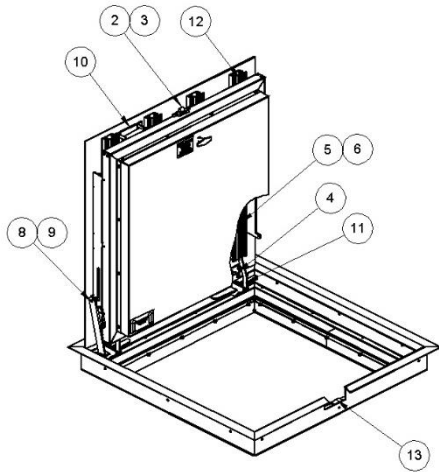

## QUESTIONS?

For more information on installation, repair or replacement, please visit [babcockdavis.com](http://babcockdavis.com)