



1-1/2 inch Vinyl Handrail

Model(s): BHRVE15C-P

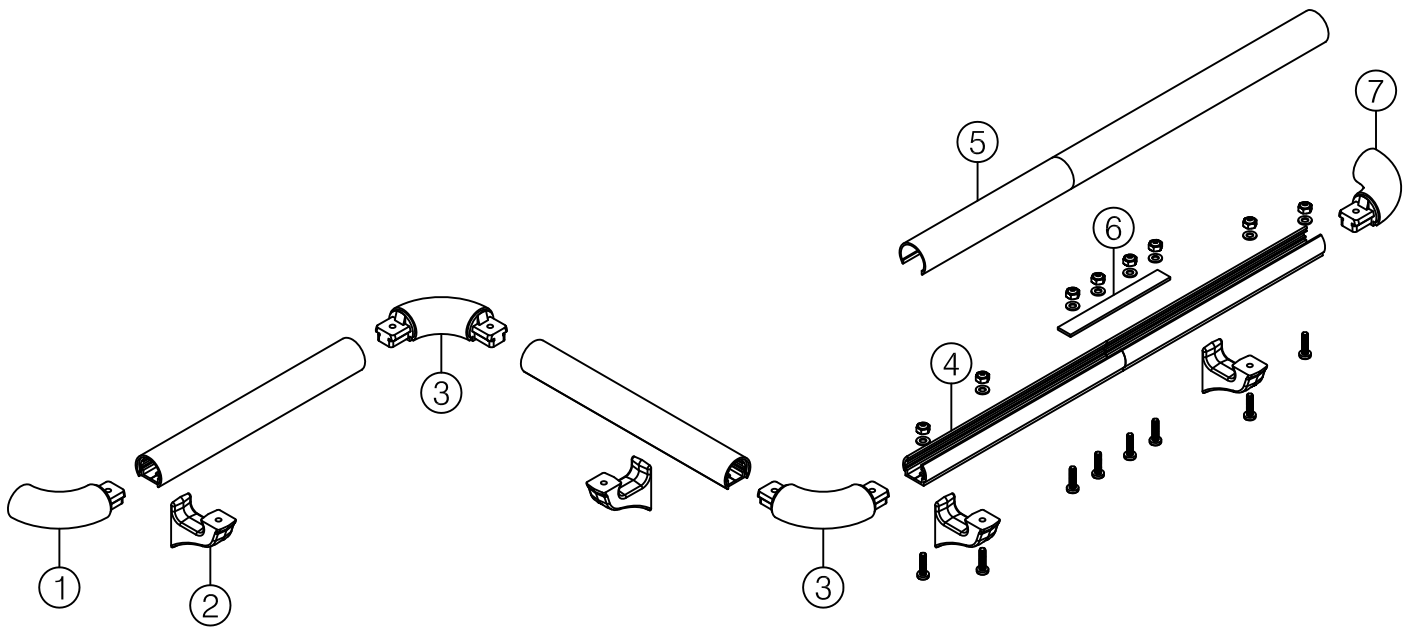

Table of Contents

General Description.....3
 Installation.....4-7
 Parts List.....8
 Maintenance.....9
 Standard Warranty.....10
 Factory Assistance.....11

Copyright

2017 by Babcock-Davis. All rights reserved.

This document contains proprietary information. No part of this document may be reproduced without the prior written consent of Babcock-Davis.

Note

The information in this document is subject to change without notice.

General Safety Precautions

Improper selection, installation, or use can cause personal injury or property damage. It is solely the responsibility of the user, through its own analysis to select products suitable for their specific application requirements, ensure they are properly maintained, and limit their use to its intended purpose.

Follow proper local, state and federal regulations for proper installation and operation requirements.

GENERAL DESCRIPTION

Recessed vinyl corner guards are designed for years of safe building use. Proper installation of the corner guards is critical to the product's performance. The following are general instructions for installing, maintaining and cleaning vinyl corner guards. These are recommended general guidelines only. Locally accepted installation practices and procedures should be followed to ensure a system that meets all local code requirements.

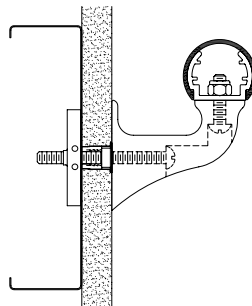

INSTALLATION

Preparation: Verify that all products listed on the packaging slip are included in the package. Check the products for damage. If product is damaged, contact customer support immediately to report a freight claim.

Store material in a clean dry place where the temperature is maintained above 50°F (10°C). Walls and rooms should be maintained at a minimum of 65°F (18°C) for at least 48 hours prior to installation. Acclimate materials to normal building conditions for at least 24 hours before cutting and installing.

Step 1 Determine top of handrail height and snap a chalk line 2-1/2 inches below for centerline of mounting hardware, see **fig. 1**.

Step 2 Cut retainer. See **Cutting Adjustment Diagrams and Schedule** for adjustments to retainer length at wall returns, inside corners and outside corners. Refer to **Minimum Layout Configurations** and **Clearance with Adjoining Construction** for additional information. All cuts must be square and deburred.

Step 3 Layout retainer “face up”, mark and drill bracket mounting hole locations. Use groove in retainer to locate centerline for drilling, see **fig. 2**. Bracket mounting holes must be spaced:

- Not to exceed 32 inches on center
- 1-1/2 inches to 6 inches from end of retainer at returns and corner accessories
- A minimum of 4 inches from end of retainer at splices to avoid interference with splice hardware (shown in **fig. 5**)
- To align with metal studs (on metal stud construction) or preferably with horizontal backer plate (by others)

Step 4 Locate and drill bracket mounting holes in wall construction using the retainer as a template or by careful measurement. Choice of hardware will dictate hole diameter.

Step 5 Insert molded accessories into end of retainer, press firmly to ensure molded part is seated squarely against the end of the retainer. Drill accessory mounting holes using the accessory as a template, see **fig. 3**.

Step 6 Attach molded returns, outside corners and inside corners to retainer with accessory seated firmly and squarely while tightening. Fasten with 1/4 inch machine screw, flat washers and nylon lock jam-nut provided.

Caution: Do not use lock washers, use flat washers only. Install a flat washer between nut and molded tab. Tighten to 10 ft-lbs maximum torque, see **fig. 4**.

INSTALLATION

Step 7 Attach brackets to retainer using 1/4 inch machine screw, flat washers and standard nylon lock nut provided. Do not tighten until rail has been mounted in place and all brackets are secured to wall.

Step 8 Mount assembly to wall with the appropriate hardware according to wall construction. See Step 9 for splicing information. Finish tightening bracket to rail fasteners to 10 ft-lbs maximum torque.

Suggested wall mount hardware

- | | |
|-----------|----------------------------|
| • Drywall | Toggler brand toggle bolts |
| • Masonry | Plastic Alligator insert |

Step 9 Refer to fig. 5 for splicing of retainer as required on longer handrail lengths. Locate splice joints a minimum of 4 inches from bracket locations to allow for clearance of splice hardware. For best results offset butt joints in cover from splice in retainer. Match drill splice plate and retainer as shown and secure with 1/4 inch - 20 fasteners provided.

Step 10 Measure between accessories (corners and returns) and cut vinyl cover. The cover is not supplied with square cut ends. All ends must be cut square by installer. Cut cover so that it will span retainer butt joints. All cuts must be square and deburred.

Step 11 Snap on vinyl cover. Install cover to span butt joints in retainer.

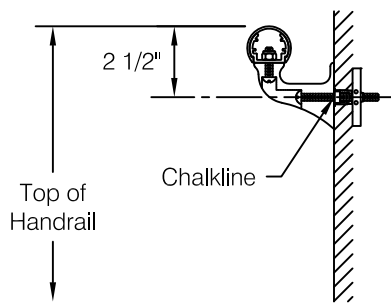

fig 1

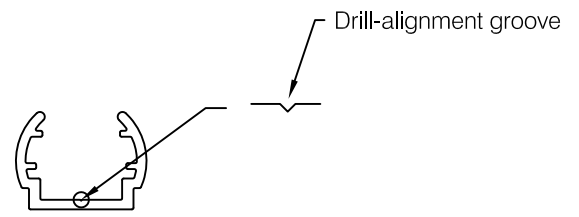

fig 2

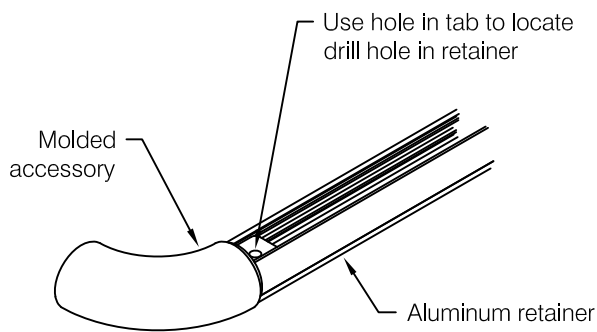

fig 3

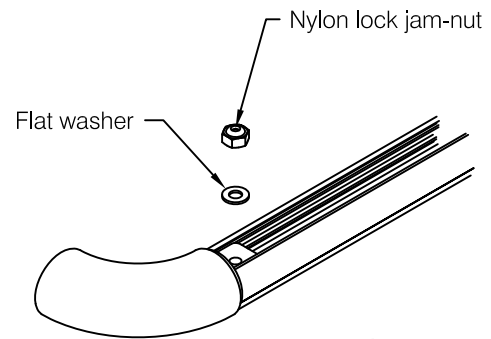

fig 4

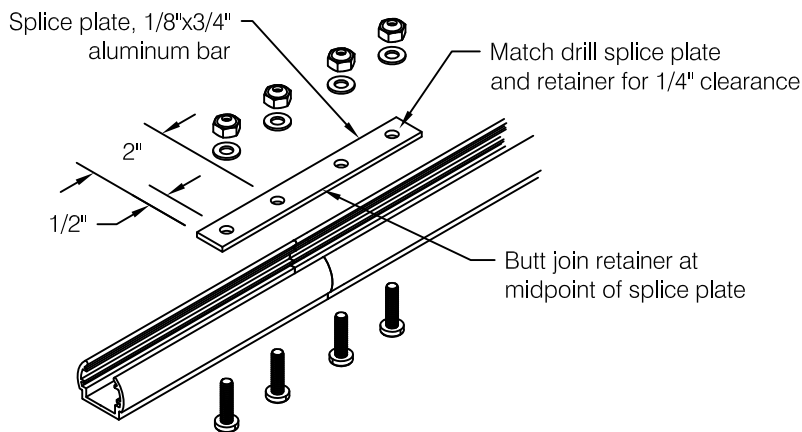
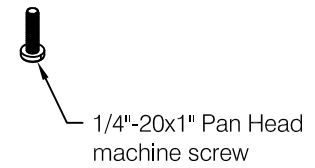
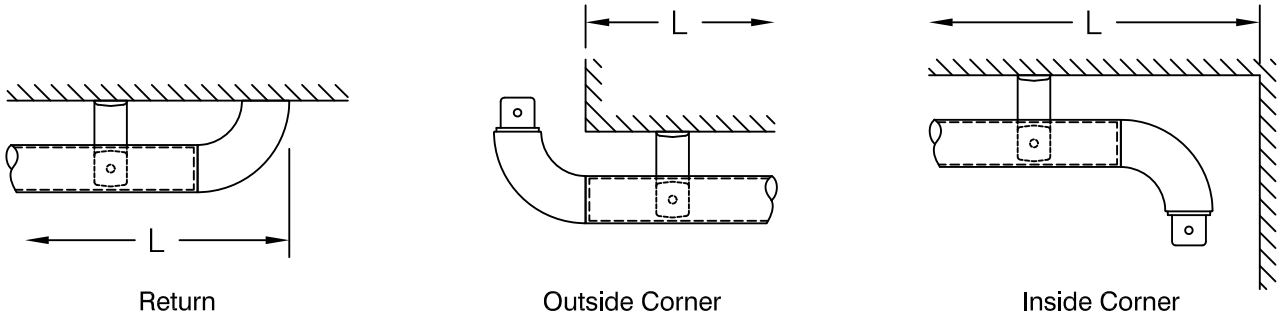

fig 5

CUTTING ADJUSTMENT DIAGRAMS AND SCHEDULE



	RETAINER	COVER
Return	L - 3-3/16"	L - 3-3/16"
Outside Corner	L - 1/8"	L - 0"
Inside Corner	L - 4-5/8"	L - 4-1/2"

Important: Install retainer and molded accessories before cutting the snap-on cover.

MINIMUM LAYOUT CONFIGURATIONS

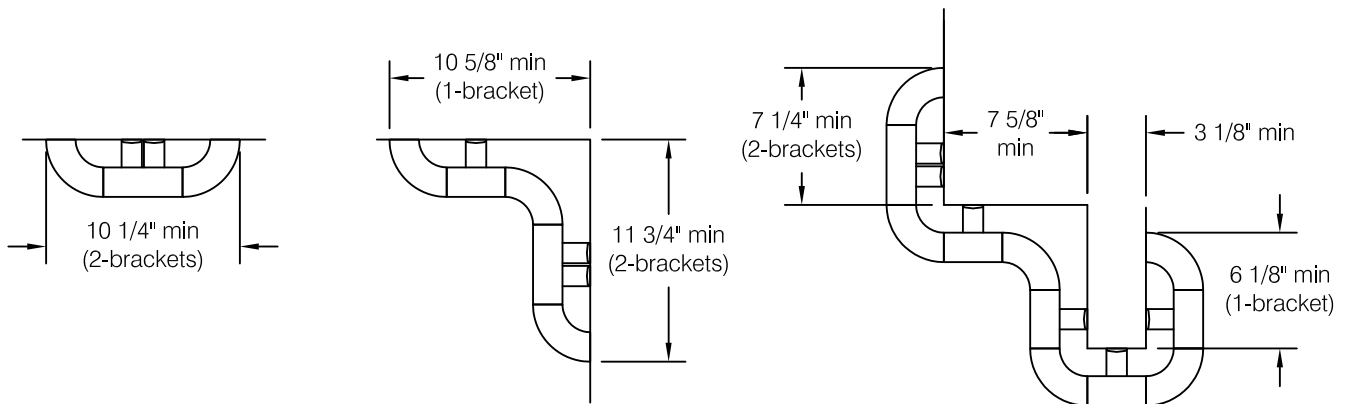

CLEARANCE WITH ADJOINING CONSTRUCTION

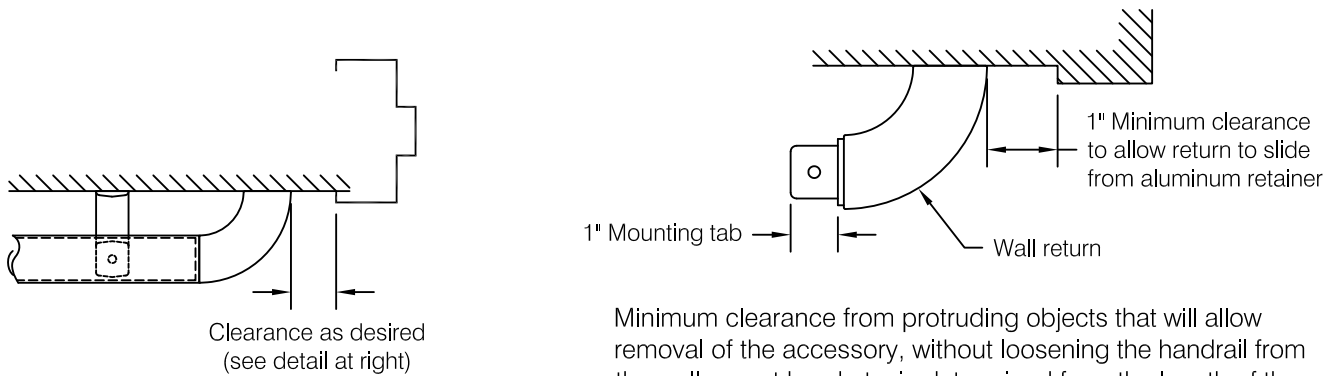

Minimum clearance from protruding objects that will allow removal of the accessory, without loosening the handrail from the wall mount brackets, is determined from the length of the mounting tab as shown.

PARTS LIST

Diagram #	Part Number	Description
1	BHRVE15C-LR-P	LEFT HAND WALL RETURN
2	BHRVE15C-BR-P	BRACKET
3	BHRVE15C-IOC-P	INSIDE/OUTSIDE CORNER
4	BHRVE15C-AR-P	ALUMINUM RETAINER
5	BHRVE15C-VC-P	VINYL COVER
6	BHRVE15C-SK-P	SPLICE
7	BHRVE15C-RR-P	RIGHT HAND WALL RETURN

When ordering, please specify color name. Current color charts are available on www.babcockdavis.com.

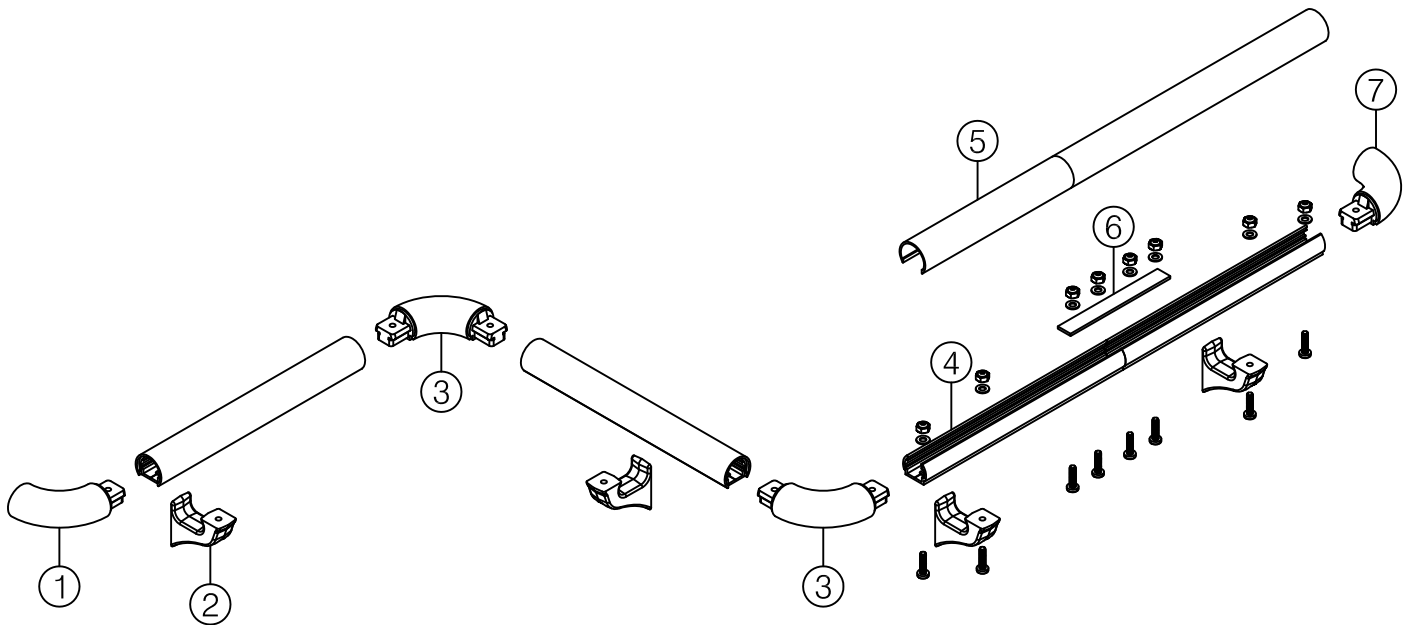

MAINTENANCE

- Do not use ammonia based cleaner, powdered cleaners or bleach; they can leave a residue if not rinsed properly. Use a liquid cleaner, such as SoftScrub without bleach, Fantastic, 409, etc., on a sponge or a soft cloth; use a stiff bristle brush to remove heavy dirt from the textured surface if necessary. Always rinse with clean water and dry with a soft cloth.
- For heavy-duty cleaning (graffiti, etc.) use a stronger cleaning agent, such as “Crown Anti-Vandal Spray”, or the equivalent. Follow the same procedures noted above, always rinsing all areas thoroughly in clean water and drying completely.
- Do not use water with extremely high temperature and do not use steam to clean vinyl because it may cause blistering and/or warping.
- Do not use abrasive cleaners or other cleaning implements, such as steel wool or cleaning pads, as they may mark or gouge the material.
- To add luster and additional protection, you can apply a thin layer of a vinyl enhancer, such as Pledge.
- Please contact manufacturer for technical support questions and/or replacement parts such as repair kits.

STANDARD WARRANTY

Babcock-Davis warrants all Wall and Door Protection to be free from manufacturing defects in materials, factory finishes and workmanship for a period of five (5) years from the date of shipment. Should a product fail to function in normal use within this period, Babcock-Davis shall furnish a replacement or new part at Babcock-Davis's discretion. Failure to use product in methods consistent with Babcock-Davis product manuals shall relieve Babcock-Davis of any liability. Our liability under this warranty excludes installation or removal costs involved in the product replacement and excludes any responsibility for incidental or consequential damage of any nature.

For warranty support and registration please visit
www.babcockdavis.com/support

FACTORY ASSISTANCE

Babcock-Davis engineers and manufactures Wall and Door Protection for worldwide customers. Our products are an integral part of commercial projects to prevent damage and safeguard your building investment. Recognized as an industry leader, Babcock-Davis has been relied upon by building and construction professions for over 100 years and we pride ourselves in offering exceptional technical support.

Please do not return any product before discussing your application problem with a Babcock-Davis representative and obtaining a Return Authorization.

Your Babcock-Davis representative is eager to help you. Please feel free to call your representative or contact Babcock-Davis to discuss your application.

Babcock-Davis
9300 73rd Avenue North
Brooklyn Park, MN 55428

Phone: 888.412.3726
Fax: 888.312.3726
Email: info@babcockdavis.com

Visit www.BabcockDavis.com for the latest version
of this document and more information.

Great Products.
Better Partners.



9300 73RD AVENUE NORTH
BROOKLYN PARK, MN 55428

(888) 412-3726
(888) 312-3726 FAX

WWW.BABCOCKDAVIS.COM