

BGL10W

QTY.	MODEL	WIDTH	LENGTH	LOCATION

RECESS OPENING DIMENSIONS:

\_\_\_\_\_ WIDTH X \_\_\_\_\_ LENGTH

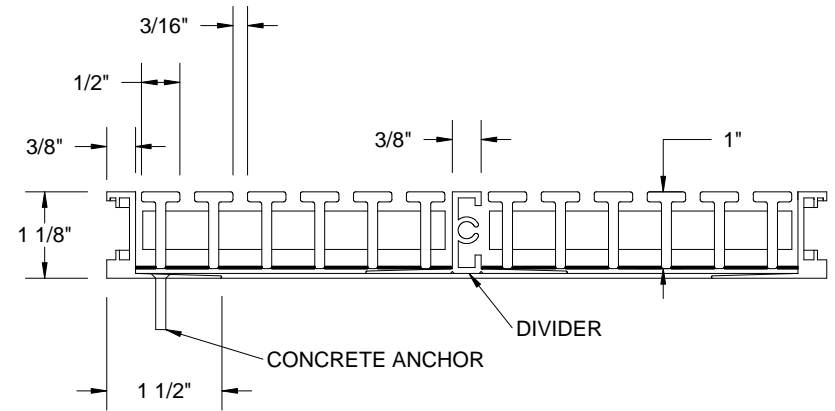
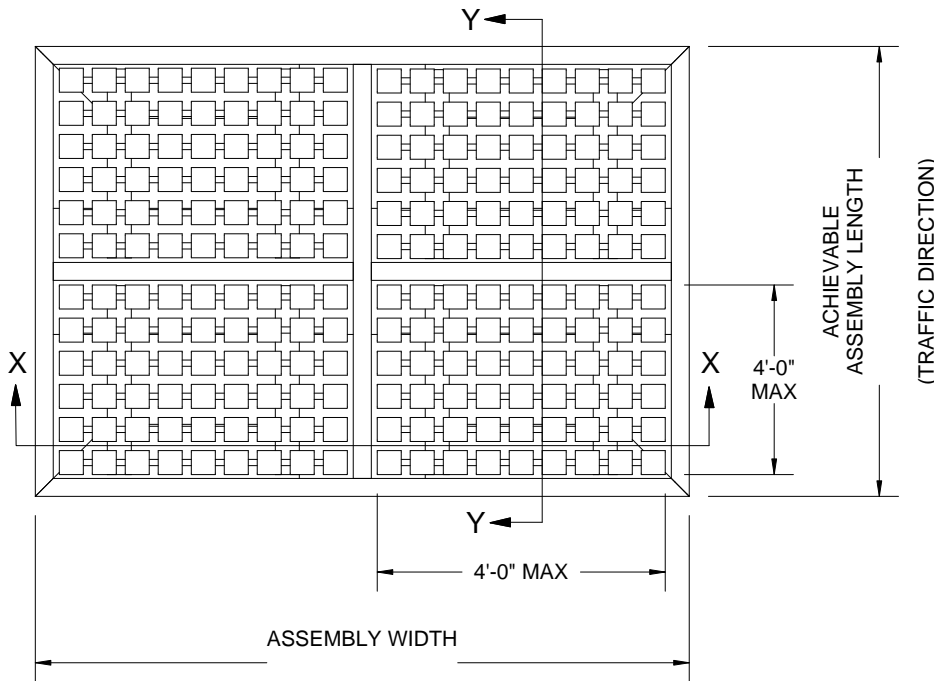

SECTION Y-Y

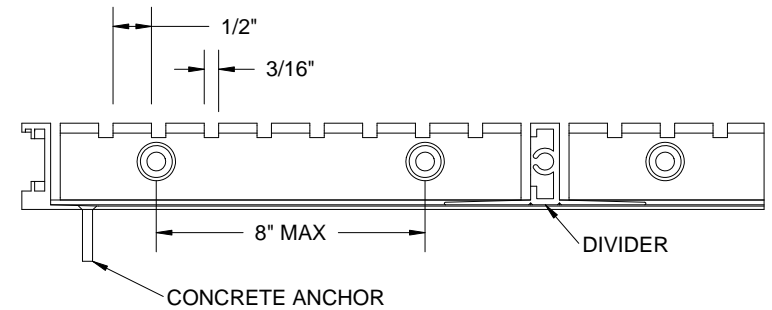

SECTION X-X

- NOTES:
- MAXIMUM GRATE SECTION SIZE NOT TO EXCEED 48" X 48"
  - GRATE MUST BE INSTALLED IN A LEVEL BED RECESS
  - RAILS ARE 6061-T6 ALUMINUM ALLOY; FRAMES ARE 6063-T6 ALUMINUM ALLOY
  - TREAD RAILS MUST RUN PERPENDICULAR TO TRAFFIC DIRECTION
  - DESIGN CLEARANCE BETWEEN GRATE AND FRAME IS 1/8"
  - ACTUAL ACHIEVEABLE GRATE LENGTH IS DEPENDANT ON BOTH NUMBER AND SIZE OF SECTIONS
  - SITE OPENING LENGTH MUST BE ADJUSTED TO GRATE AND FRAME ACHIEVEABLE LENGTH
  - ADDITIONAL INFORMATION CAN BE FOUND IN THE PRODUCT SPECIFICATION AND IS CONSIDERED PART OF THIS TRANSMITTAL

PROJECT:					
ARCHITECT:					
CONTRACTOR:					
QTY:		<b>BGL10W</b>			
PART#:		<b>BFL10LBM</b>			
 9300 73rd Avenue North Brooklyn Park, MN 55428		TITLE: AlumaGRIL Grate Level Bed Mechanically Fastened Frame Waffle Cut Grate			
	NAME	DATE	SIZE	DWG. NO.	REV
DRAWN	DKL	01/12/18	A	Babcock EFS BGL10W-LBM ShpDr	A
RELEASED	DT	01/12/18	WEIGHT:	SHEET 1 OF 1	