

BGL10W

QTY.	MODEL	WIDTH	LENGTH	LOCATION

RECESS OPENING DIMENSIONS:

_____ WIDTH X _____ LENGTH

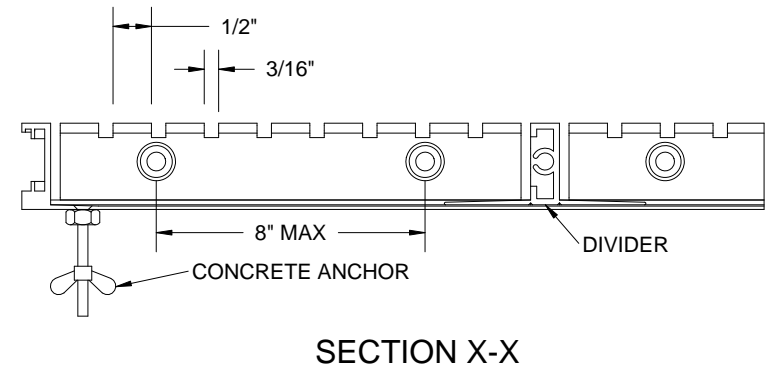
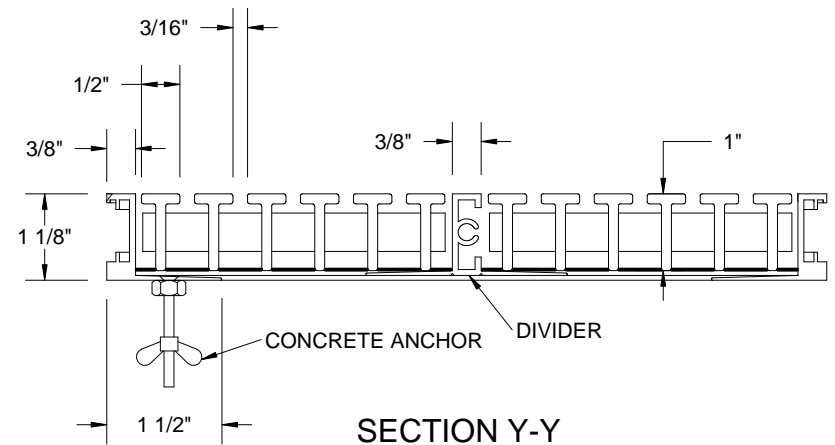
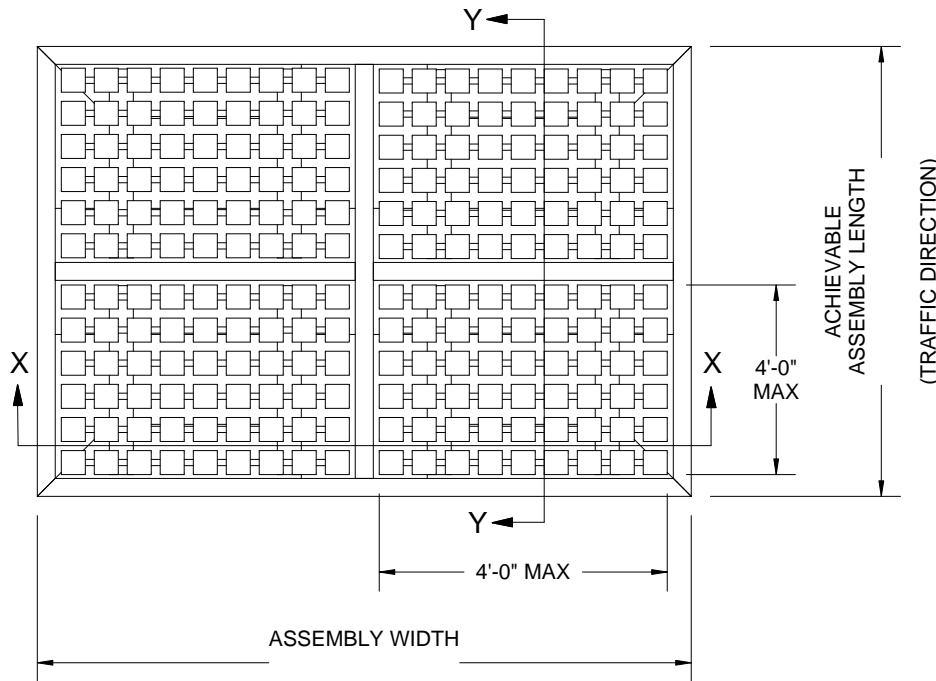

- NOTES:
- MAXIMUM GRATE SECTION SIZE NOT TO EXCEED 48" X 48"
 - GRATE MUST BE INSTALLED IN A LEVEL BED RECESS
 - RAILS ARE 6061-T6 ALUMINUM ALLOY; FRAMES ARE 6063-T6 ALUMINUM ALLOY
 - TREAD RAILS MUST RUN PERPENDICULAR TO TRAFFIC DIRECTION
 - DESIGN CLEARANCE BETWEEN GRATE AND FRAME IS 1/8"
 - ACTUAL ACHIEVEABLE GRATE LENGTH IS DEPENDANT ON BOTH NUMBER AND SIZE OF SECTIONS
 - SITE OPENING LENGTH MUST BE ADJUSTED TO GRATE AND FRAME ACHIEVEABLE LENGTH
 - ADDITIONAL INFORMATION CAN BE FOUND IN THE PRODUCT SPECIFICATION AND IS CONSIDERED PART OF THIS TRANSMITTAL

PROJECT:			
ARCHITECT:			
CONTRACTOR:			
QTY:		BGL10W	
PART#:		BFL10LBC	
<p>9300 73rd Avenue North Brooklyn Park, MN 55428</p>		TITLE: AlumagrIL Grate Level Bed Cast In Frame Waffle Cut Grate	
NAME	DATE	SIZE	DWG. NO.
DRAWN	DKL	01/12/18	A
RELEASED	DT	01/12/18	WEIGHT:
			REV
			A
			SHEET 1 OF 1