

QTY	MODEL	WIDTH	LENGTH	FINISH	LOCATION

B

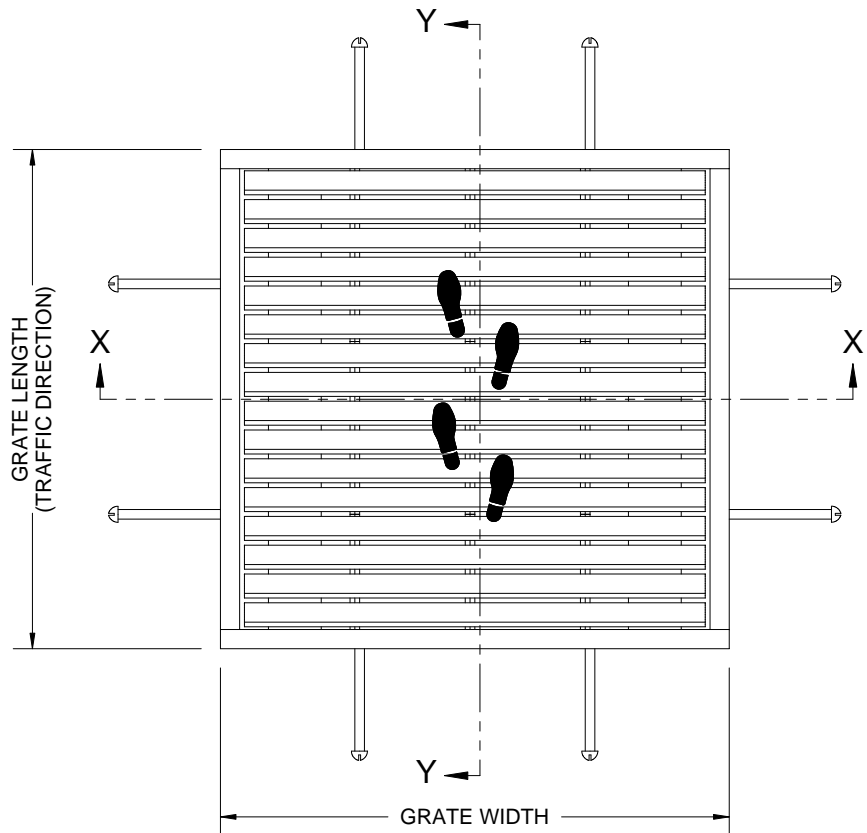

B

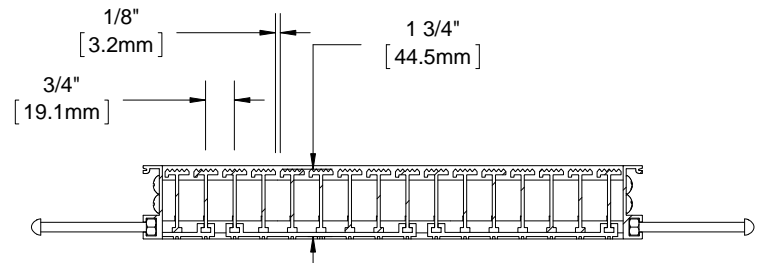

SECTION Y-Y

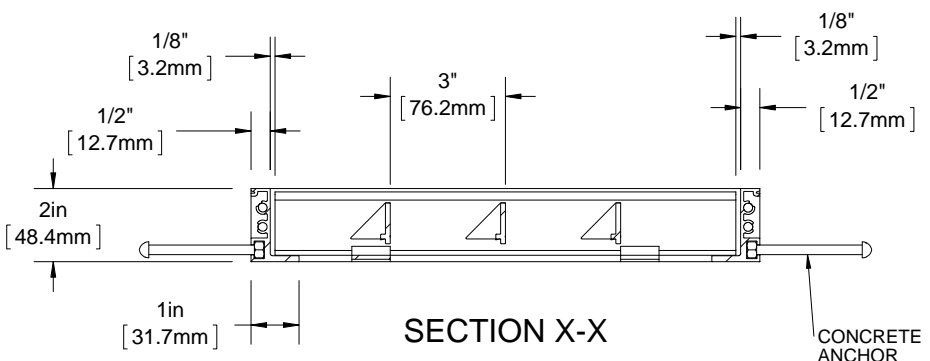

SECTION X-X

- NOTES:**
- STANDARD MAXIMUM SECTION SIZE OF GRATE WIDTH NOT TO EXCEED 8'-0", CUSTOM SECTIONING AVAILABLE
 - FRAME ANCHOR SPACING: 6" FROM CORNERS, 24" MAX
 - VERIFY TRAFFIC DIRECTION AND THAT SECTIONING DOES NOT OCCUR IN A TRAFFIC LANE
 - ALL RAIL COMPONENTS ARE MADE OF 6063-T6 ALUMINUM ALLOY, ALL FRAME COMPONENTS ARE MADE OF 6063-T5 ALUMINUM ALLOY. KEYLOCKS ARE MADE WITH 6061-T6 ALUMINUM ALLOY
 - TREAD RAILS MUST RUN PERPENDICULAR TO TRAFFIC DIRECTION
 - TRAFFIC DIRECTION DIMENSION CAN ONLY BE CHANGE IN 3/4" (19.1 MM) INCREMENTS UNLESS OPTIONAL ALUMINUM FILLER IS INCLUDED
 - GRATE DIMENSION ALLOWS FOR CLEARANCE BETWEEN GRATE SECTIONS AND FRAMES IN THE WIDTH DIMENSION
 - ADDITIONAL INFORMATION CAN BE FOUND IN THE PRODUCT SPECIFICATION AND IS CONSIDERED PART OF THIS TRANSMITTAL.
 - FRAME MODEL NUMBER: BFD74LBC

PROJECT:				DESCRIPTION:	
ARCHITECT:				GRATEdesign® 1 3/4" Aluminum Grate with Cast-In, Level Bed, Aluminum, Frame	
CONTRACTOR:				DWG NO. BGD74L-FLBC	
 9300 73rd Avenue North Brooklyn Park, MN 55428				SCALE: NTS	
NAME	DATE	SIZE	REV A		
DRAWN: DKL	5/11/15	A	SHEET 1 OF 1		
RELEASED: PE	5/11/15	SCALE: NTS	REV A		

PROPRIETARY AND CONFIDENTIAL: THE INFORMATION CONTAINED IN THIS DRAWING IS THE SOLE PROPERTY OF BABCOCK-DAVIS. ANY REPRODUCTION IN PART OR AS A WHOLE WITHOUT THE WRITTEN PERMISSION OF BABCOCK-DAVIS IS PROHIBITED.