

BGA10R

QTY	MODEL	WIDTH	LENGTH	FINISH	LOCATION

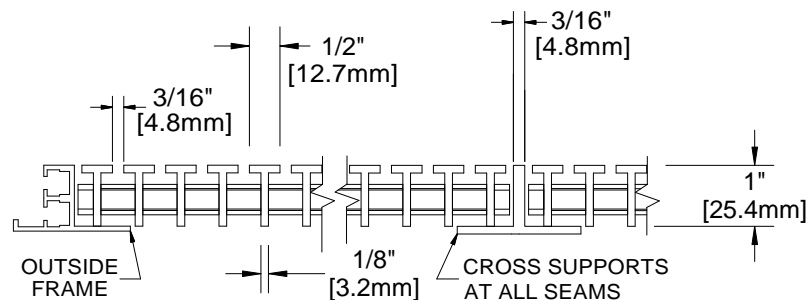

SECTION Y-Y

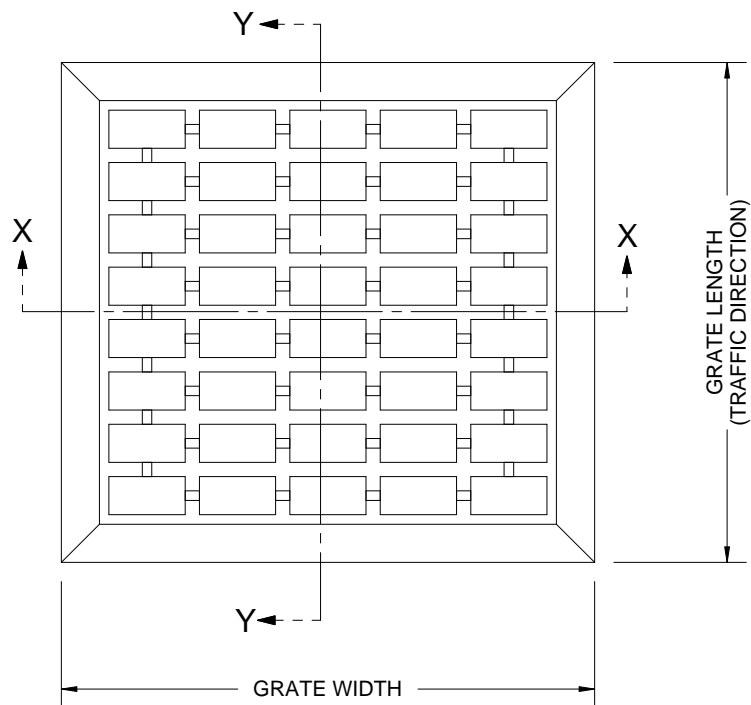
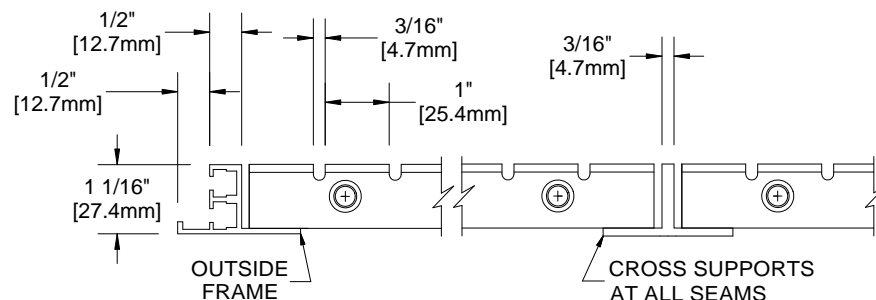

SECTION X-X

- NOTES:
- STANDARD MAXIMUM SECTION SIZE OF GRATE LENGTH/WIDTH NOT TO EXCEED 4'-0"
  - VERIFY TRAFFIC DIRECTION AND THAT SECTIONING DOES NOT OCCUR IN A TRAFFIC LANE
  - ALL RAIL COMPONENTS ARE MADE OF 6061-T6 ALUMINUM ALLOY, ALL FRAME COMPONENTS ARE MADE OF 6061-T6 ALUMINUM ALLOY
  - TREAD RAILS MUST RUN PERPENDICULAR TO TRAFFIC DIRECTION
  - GRATE DIMENSION ALLOWS FOR CLEARANCE BETWEEN GRATE SECTIONS AND FRAMES, 1/8" ± 1/16" ALL AROUND
  - ADDITIONAL INFORMATION CAN BE FOUND IN THE PRODUCT SPECIFICATION AND IS CONSIDERED PART OF THIS TRANSMITTAL.
  - FRAME PART NUMBER: BFA10LBC

PROJECT:					
ARCHITECT:					
CONTRACTOR:					
 9300 73rd Avenue North Brooklyn Park, MN 55428			DESCRIPTION:		
			Alumagril™, 1" Aluminum Rectangular Waffle Grate with Level Bed, Cast-In, Aluminum Frame		
	NAME	DATE	SIZE	DWG. NO.	
DRAWN	DKL	4/13/15	A	BGA10R-FLBC	
RELEASED	PE	4/13/15	SCALE: NTS	SHEET 1 OF 1	REV A