

**SPECIFICATIONS:**

- ① **DOOR:**  
STEEL 3/16" DIAMOND PLATE, GRAY PRIMER FINISH WITH A LIVE LOAD OF 300 PSF WITH A MAX SPAN DEFLECTION OF 1/150
- ② **FRAME:**  
STEEL 3/16" FORMED SMOOTH PLATE, GRAY PRIMER FINISH
- ③ **HINGES:** TYPE 316 STAINLESS STEEL
- ④ **SLAM LATCH:**  
TYPE 316 STAINLESS STEEL WITH INSIDE LEVER HANDLE AND OUTSIDE REMOVABLE HANDLE
- ⑤ **COUNTER-BALANCE SPRING:**  
ENCLOSED, TYPE 17-7 SST SPRING
- ⑥ **HOLD-OPEN ARM:**  
TYPE 316 STAINLESS STEEL WITH RED VINYL GRIP HANDLE

- ⑦ **DRAINAGE COUPLING:** 1-1/2"
- ⑧ **FLUSH TYPE PLUG SEAL:** TYPE 316 STAINLESS STEEL
- ⑨ **ANCHOR:** 4" CONCRETE ANCHOR STRAPS

FLOOR DOOR SIZE:

PROPRIETARY AND CONFIDENTIAL: THE INFORMATION CONTAINED IN THIS DRAWING IS THE SOLE PROPERTY OF BABCOCK-DAVIS. ANY REPRODUCTION IN PART OR AS A WHOLE WITHOUT THE WRITTEN PERMISSION OF BABCOCK-DAVIS IS PROHIBITED.

PROJECT:				
ARCHITECT:				
CONTRACTOR:				
QTY:				
PART#:				
		TITLE: Floor Door, Drainable Series, Dbl Dr, 316 SST Hdw, Steel, Prime Coat, Pedestrian, Cast-In Anchors, Slam Latch Removbl L Hdl,		
		9300 73rd Avenue North, Brooklyn Park, MN 55428		
NAME	DATE	SIZE	DWG. NO.	REV
DRAWN BES	12/4/2018	A	Babcock FD BFDDPP_X_DWL ShpDr	A
RELEASED	BES	12/4/2018	WEIGHT:	SHEET 1 OF 2

B

B

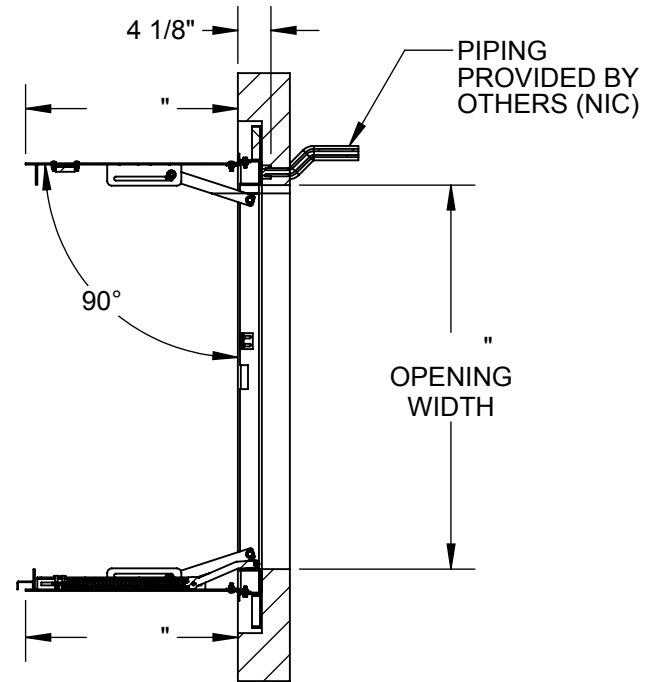
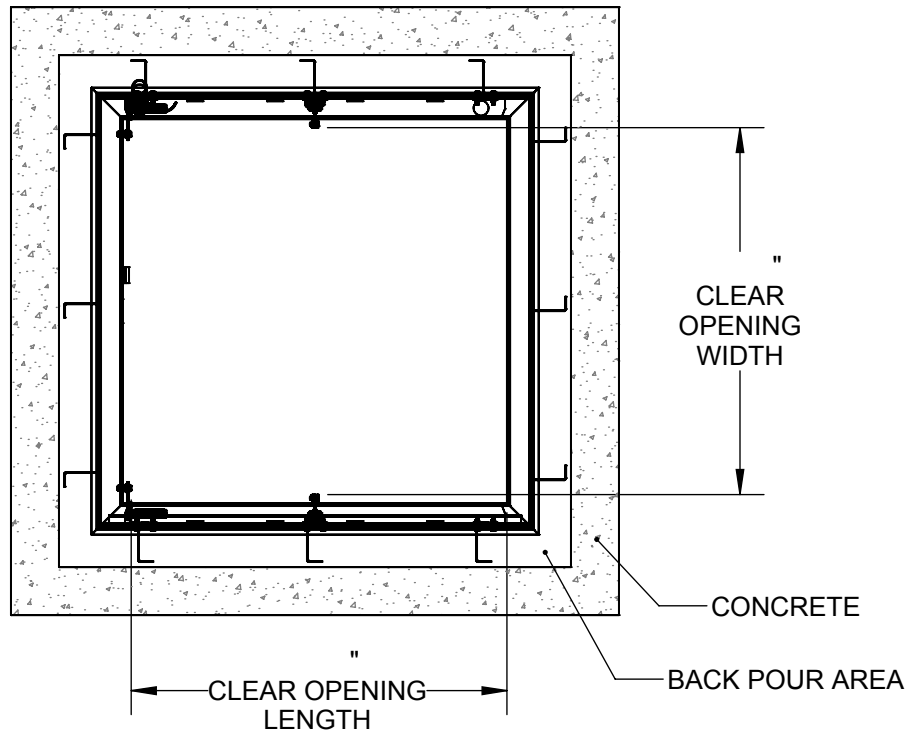

A

A

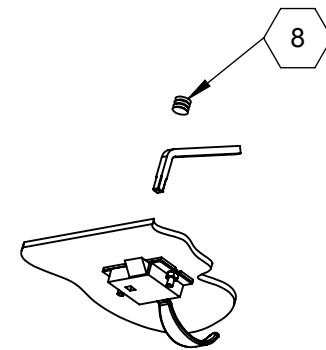
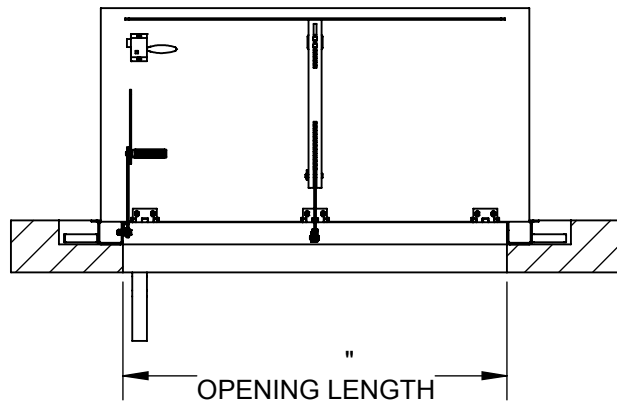

**SLAM LATCH DETAIL**

			TITLE: Floor Door, Drainable Series, Dbl Dr, 316 SST Hdw, Steel, Prime Coat, Pedestrian, Cast-In Anchors, Slam Latch Removbl L Hdl,		
9300 73rd Avenue North Brooklyn Park, MN 55428			DWG. NO.	REV	
DRAWN	BES	12/4/2018	A	Babcock FD BFDDPP_X_DWL ShpDr A	
RELEASED	BES	12/4/2018	WEIGHT:	SHEET 2 OF 2	