

QUANTITY

COLOR

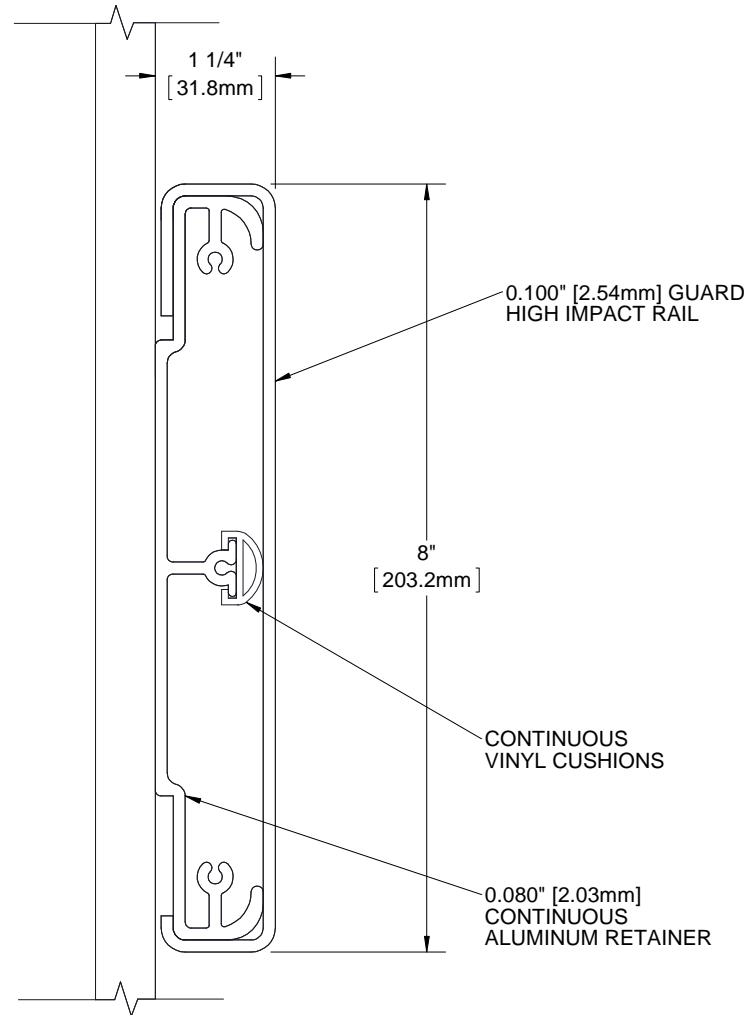

NOTES:

1. **PROFILE:** HIGH IMPACT VINYL ACRYLIC EXTRUSION LOCKED IN PLACE, NOMINAL 0.100" (2.54mm) THICK
2. CLASS A FIRE RATING, TESTED TO ASTM E84
3. **RETAINER:** CONTINUOUS 6063 T-5 ALUMINUM RETAINER, NOMINAL 0.080" (2.03mm) THICK
4. **EXTRUSION:** PEBBLE GRAIN FINISH WHICH CONTAINS EPA REGISTERED MICRO-CHEK ANTIMICROBIAL AGENT
5. **VINYL CRASH RAIL LENGTH:** PROVIDED IN 20' CONTINUOUS SECTIONS
6. END CAP: #BCRVS8C-EC, OUTSIDE CORNER: #BCRVS8C-OC, 135 DEG OUTSIDE CORNER: #BCRVS8C-OC135, INSIDE CORNER: #BCRVS8C-IC, SPLICE KIT: #BCRVS8C-SK
7. FASTENERS AND PARTITION COMPONENTS PROVIDED BY OTHERS.

PROPRIETARY AND CONFIDENTIAL: THE INFORMATION CONTAINED IN THIS DRAWING IS THE SOLE PROPERTY OF BABCOCK-DAVIS. ANY REPRODUCTION IN PART OR AS A WHOLE WITHOUT THE WRITTEN PERMISSION OF BABCOCK-DAVIS IS PROHIBITED.

PROJECT:					
ARCHITECT:					
CONTRACTOR:					
 9300 73rd Avenue North Brooklyn Park, MN 55428		TITLE: 8" VINYL CRASH RAIL SURFACE MOUNT CONTINUOUS RETAINER			
		NAME	DATE	SIZE	DWG. NO.
DRAWN	MDS	23APR13	A	BCRVS8C	A
RELEASED	PGE	01MAY13	WEIGHT: 2.25 lbs/ft	SHEET 1 OF 1	