

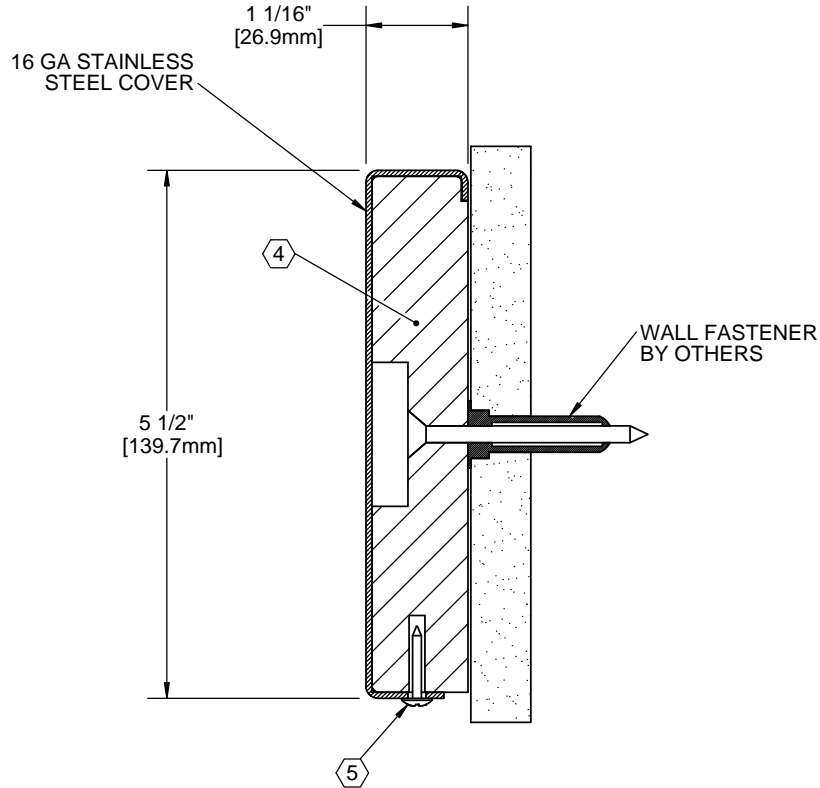

QUANTITY	LENGTH



NOTES:

- 1. SURFACE MOUNT APPLICATION
- 2. MATERIAL: TYPE 304 STAINLESS STEEL, 16 GAUGE
- 3. FINISH: SATIN #4
- ④ RETAINER: WOOD RAIL
- ⑤ #6 X 3/4" SECURING SCREW, INCLUDED.
- 6. PROVIDED IN 10' CONTINUOUS SECTIONS
- 7. END CAP: #CRSS55-EC
- 8. PARTITION COMPONENTS BY OTHERS.

PROJECT:					
ARCHITECT:					
CONTRACTOR:					
 9300 73rd Avenue North Brooklyn Park, MN 55428		TITLE:			
		5.5" SS CRASH RAIL, TYPE 304, 16 GA, SURFACE MOUNT, WOOD RETAINER, #4 FINISH			
	NAME	DATE	SIZE	DWG. NO.	REV
DRAWN	DKL	5/7/14	A	BCRSS55	A
RELEASED	PGE	5/7/14	WEIGHT: 3.0 LB/LF	SHEET 1 OF 1	