

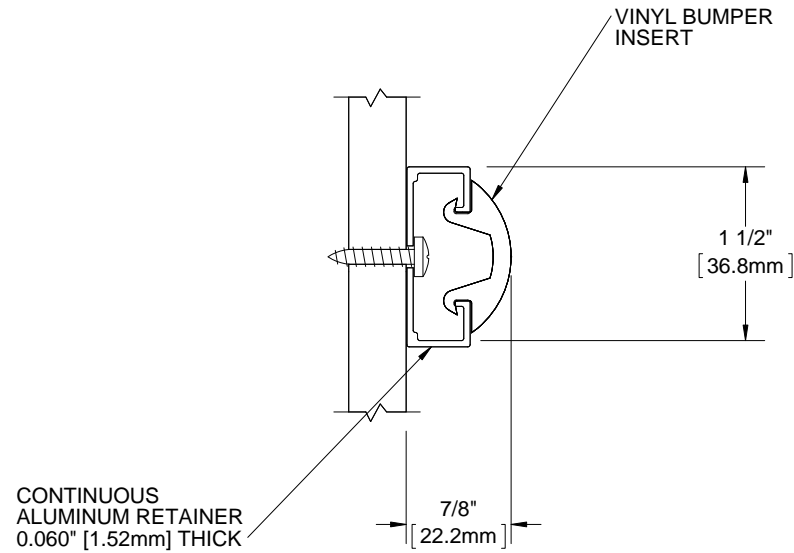

QUANTITY

COLOR



NOTES:

- 1. **PROFILE:** FLEXIBLE VINYL EXTRUSION LOCKED IN PLACE.
- 2. CLASS A FIRE RATING, TESTED TO ASTM E84
- 3. **RETAINER:** CONTINUOUS ALUMINUM RETAINER, NOMINAL 0.060" (1.52mm) THICK.
- 4. **EXTRUSION:** SMOOTH SATIN FINISH
- 5. **VINYL BUMPER GUARD LENGTH:** PROVIDED IN 20' CONTINUOUS SECTIONS
- 6. END CAP: #BBGVS15C-EC, OUTSIDE CORNER: #BBGVS15C-OC
- 7. FASTENERS AND PARTITION COMPONENTS PROVIDED BY OTHERS.

PROJECT:					
ARCHITECT:					
CONTRACTOR:					
 9300 73rd Avenue North Brooklyn Park, MN 55428		TITLE: 1-1/2" VINYL BUMPER GUARD SURFACE MOUNT MILL FINISH RETAINER			
		NAME	DATE	SIZE	DWG. NO.
DRAWN	MDS	26APR13	A	BBGVS15C-RFM	A
RELEASED	PGE	01MAY13	WEIGHT: 0.43 LBS/FT	SHEET 1 OF 1	