

FRONT ELEVATION  
NOT TO SCALE

### SPECIFICATIONS

- 12 GAUGE COLD ROLLED STEEL FRAME
- 12 GAUGE COLD ROLLED STEEL DOOR
- 22 GAUGE GALVANIZED STEEL DRYWALL BEAD
- WHITE BAKED ON POWDER COAT FINISH
- CONCEALED CONTINUOUS HINGE
- FRAMES ARE PROVIDED WITH .25" MOUNTING HOLES
- PINNED ALLEN HEAD SECURITY CAM LATCH  
(ADDITIONAL CAMS PROVIDED ON PANELS 18" X 18" AND GREATER IN SIZE)

### OPTIONS

- GALVANIZED BONDERIZED STEEL
- MASONRY ANCHORS
- STAINLESS STEEL WITH A #4 SATIN POLISH FINISH

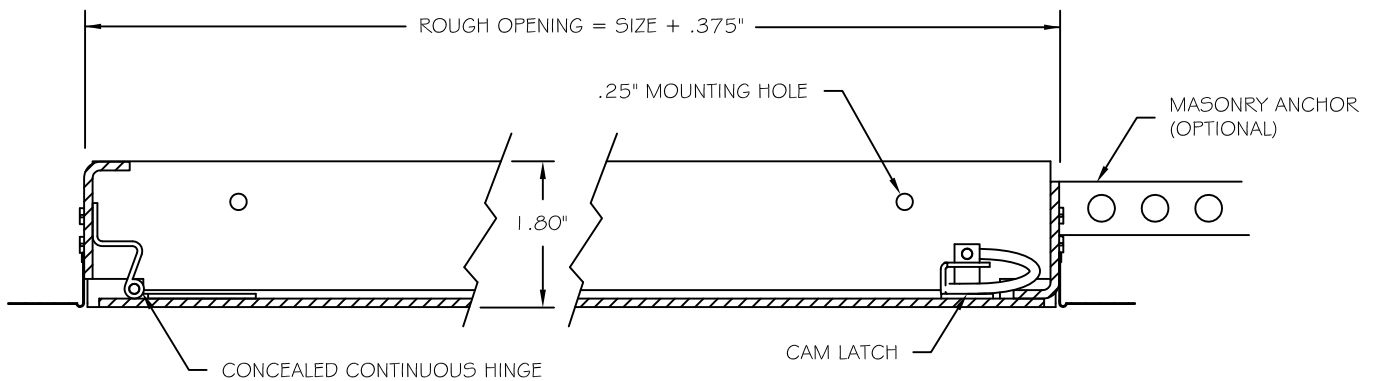

CUT-THRU SECTION  
NOT TO SCALE



9300 73RD AVENUE NORTH  
BROOKLYN PARK, MN 55428

PH. (888) 412-3726  
WWW.BABCOCKDAVIS.COM

Standard Features:

Door: 12 gauge cold rolled steel  
Frame: 12 gauge cold rolled steel with 22 ga galvanized drywall corner bead  
Hinge: Concealed continuous hinge  
Latch: Pinned allen head security cam latch(es)  
Finish: White baked on powder coat  
Optional: galvanized bonderized or stainless steel with #4 satin polish finish

---

Specifications:

Frame shall be 12 gauge cold rolled steel with 22 gauge galvanized drywall corner bead. Door shall be fabricated from 12 gauge cold rolled steel. Hinge shall be concealed continuous hinge. Latch(es) shall be pinned allen head security cam latch(es). Finish shall be white baked on powder coat (optional: galvanized bonderized steel or stainless steel with #4 satin polish finish).

Installation shall be in accordance with manufacturers instructions. Manufacturer shall guarantee against defects in material and workmanship for a period of one year.

---

Standard Sizes:

Std Sizes (in)	Std Sizes (mm)	Weight/Latches	Std Sizes (in)	Std Sizes (mm)	Weight/Latches
06x06*	152x152	18/1	20x30	508x762	56/3
08x08	203x203	20/1	22x22	559x559	49/2
10x10	254x254	23/1	22x30	559x762	58/3
12x12	305x305	24/1	24x24	610x610	52/4
12x18	305x457	30/1	24x30	610x762	60/5
12x24	305x610	35/2	24x36	610x914	68/5
14x14	356x356	26/1	24x48	610x1219	94/5
16x16	406x406	32/1	30x30	762x762	70/5
16x20	406x508	36/2	32x32	813x813	76/5
18x18	457x457	36/2	36x36	914x914	95/6
18x24	457x610	48/2	36x48	914x1219	123/6

\* Sizes specified have only cam style latching options.

All units are hinged on the second dimension (height). Rough opening is door size plus 1/4".